

AGENDA

For the Council Meeting to be held on

Tuesday 14 May, 2019

Commencing at 6:00 p.m.

In the Council Chambers, Ravensthorpe.



SHIRE OF RAVENSTHORPE

DISCLAIMER

No responsibility whatsoever is implied or accepted by the Ravensthorpe Shire Council for any act, omission or statement or intimation occurring during Council/Committee meetings or during formal/informal conversations with staff. The Ravensthorpe Shire Council disclaims any liability for any loss whatsoever and howsoever caused arising out of reliance by any person or legal entity on any such act, omission or statement or intimation occurring during Council/Committee meetings or discussions. Any person or legal entity that act or fails to act in reliance upon any statement does so at that person's or legal entity's own risk.

In particular and without derogating in any way from the broad disclaimer above, in any discussion regarding any planning application or application for a licence, any statement or limitation of approval made by a member or officer of Ravensthorpe Shire Council during the course of any meeting is not intended to be and is not taken as notice of approval from the Ravensthorpe Shire Council. The Ravensthorpe Shire Council warns that anyone who has an application lodged with the Ravensthorpe Shire Council must obtain and only should rely on **WRITTEN CONFIRMATION** of the outcome of the application, and any conditions attaching to the decision made by the Ravensthorpe Shire Council in respect of the application.

A handwritten signature in black ink, appearing to be "G. Pollock", is written over a horizontal line.

Gavin Pollock
Chief Executive Officer

3/5/2019

65 Morgans Street Ravensthorpe WA 6346
Tel (08) 98390000; Fax (08) 98381282
E-mail: - shire@ravensthorpe.wa.gov.au



WRITTEN DECLARATION OF INTEREST IN MATTER BEFORE COUNCIL

NOTE: USE ONE FORM PER DECLARATION

I, (1) _____ wish to declare an interest in the following item to be considered by council at its meeting to be held on (2)

Agenda item (3) _____

The type of interest I wish to declare is (4)

- Financial pursuant to Sections 5.60A of the Local Government Act 1995
- Proximity pursuant to Section 5.60B of the Local Government Act 1995
- Indirect Financial pursuant to Section 5.61 of the Local Government Act 1995
- Impartiality pursuant to Regulation 11 of the Local Government (Rules of Conduct) Regulation 2007

The nature of my interest is (5)

The extent of my interest is (6)

I understand that the above information will be recorded in the Minutes of the meeting and recorded by the Chief Executive Officer in an appropriate Register.

Signature

Date

RECEIVED BY:

Chief Executive Officer

Date

- (1) Insert you name.
- (2) Insert the date of the Council Meeting at which the item it to be considered.
- (3) Insert the Agenda Item Number and Title.
- (4) Tick the box to indicate the type of interest.
- (5) Describe the nature of your interest.
- (6) Describe the extent of your interest (if seeking to participate in the matter under the s.5.68 of the Act)

Financial pursuant to Sections 5.60A of the Local Government Act 1995**5.60A – Financial Interest**

For the purpose of this Subdivision, a person has a financial interest in a matter if it is reasonable to expect that the matter will if dealt with by the local government, or an employee or committee of the local government or member of the council of the local government, in a particular way, result in a financial gain, loss, benefit or detriment for the person.

[Section 5.60A inserted by No. 64 of 1998 s. 30; amended by No. 49 of 2004 s. 50.]

Proximity pursuant to Section 5.60B of the Local government Act 1995**5.60B – Proximity Interest**

- (1). For the purposes of this Subdivision, a person has a proximity interest in a matter if the matter concerns –
 - (a). a proposed change to a planning scheme affecting land that adjoins the person's land;
 - (b). a proposed change to zoning or use of land that adjoins that person's land; or
 - (c). a proposed development (as defined in section 5.63 (5)) of land that adjoins the person's land.
- (2). In this section, land ("**the proposal land**") adjoins a person's land if –
 - (a). the proposal land, not being a thoroughfare, has a common boundary with the person's land;
 - (b). the proposal land, or any part of it, is directly across a thoroughfare from, the person's land; or
 - (c). the proposal land is that part of a thoroughfare that has a common boundary with the person's land.
- (3). In this section a reference to a person's land is a reference to any land owned by the person or in which the person has any estate or interest.

[Section 5.60B inserted by No 64 of 1998 s. 30.]

Indirect Financial pursuant to Section 5.61 of the Local Government Act 1995**5.61 – Indirect financial interest**

A reference in this Subdivision to an indirect financial interest of a person in a matter includes a reference to a financial relationship between that person and another person who requires a local government decision in relation to the matter.

Impartiality pursuant to Regulation 11 of the Local Government (Rules of Conduct) Regulation 2007**11 – Disclosure of interest**

- (1). In this regulation –
Interest means an interest that could, or could reasonably be perceived to; adversely affect the impartiality of the person having the interest arising from kinship friendship or membership of an association.
- (2). A person who is a council member and who has an interest in any matter to be discussed at a council or committee meeting attended by the member must disclose the nature of the interest –
 - (a). in a written notice given to the CEO before the meeting;or

- (b). at the meeting immediately before the matter is discussed.
- (3). Sub-regulation (2) does not apply to an interest referred to in section 5.60 of the Act.
- (4). Sub-regulation (2) does not apply if –
 - (a). A person who is a council member fails to disclose an interest because the person did not know he or she has an interest in the matter; or
 - (b). A person who is a council member fails to disclose an interest because the person did not know the matter in which he or she had an interest would be discussed at the meeting and the person disclosed the interest as soon as possible after the discussion began.
- (5). If, under sub-regulation (2)(a), a person who is a council member discloses an interest in a written notice given to the CEO before a meeting then –
 - (a). Before the meeting the CEO is to cause the notice to be given to the person who is to preside at the meeting; and
 - (b). At the meeting the person presiding is to bring the notice and its contents to the attention of the persons present immediately before a matter to which the disclosure related is discussed.
- (6). If –
 - (a). Under sub-regulation (2)(b) or (4)(b) a person's interest in a matter is disclosed at a meeting; or
 - (b). Under sub-regulation (5) (b) notice of a person's interest in a matter is brought to the attention of the persons present at a meeting.

The nature of the interest is to be recorded in the minutes of the meeting.

Describe the extent of your interest (If seeking to participate in the matter under the s.5.68 of the act)

5.68 – Councils and committees may allow members disclosing interests to participate etc. in meetings

- (1). If a member has disclosed, under section 5.65, an interest in a matter, the members present at the meeting who are entitled to vote on the matter
 - (a). may allow the disclosing member to be present during any discussion or decision making procedure relating to the matter; and
 - (b). may allow , to the extent decided by those members, the disclosing member to preside at the meeting (if otherwise qualified to preside) or to participate in discussions and the decision making procedures relating to the matter if –
 - (i) the disclosing member also discloses the extent of the interest; and
 - (ii) those members decide that the interest –
 - (I) is so trivial or insignificant as to be unlikely to influence the disclosing member's conduct in relation to the matter; or
 - (II) is common to a significant number of electors or ratepayers
- (2). A decision under this section is to be recorded in the minutes of the meeting relating to the matter together with the extent of any participation allowed by the council or committee.
- (3). This sections does not prevent the disclosing member from discussing, or participating in the decision making process on, the question on whether an application should be made to the Minister under section 5.69.



**SHIRE OF RAVENSTHORPE
WORKS REQUEST FORM**

Name: _____

Date: ____/____/2018 Urgency: Low / Medium / High / Strategic

Road / Public Building / Area: _____

Request: _____

Description:

OFFICE USE ONLY:

Action Taken:

Comment:

Completed: ____/____/2018 Signature: _____

Inspected and/or authorised: _____
Chief Executive Officer



Application for Leave of Absence

(Pursuant to Section 2.25 of the Local Government Act 1995 (as amended))

- (1) A council may, by resolution, grant leave of absence to a member.
- (2) Leave is not to be granted to a member in respect to more than 6 consecutive ordinary meetings of the Council without the approval of the Minister.
- (3) The granting of the leave is to be recorded in the minutes of the meeting.
- (4) A member who is absent without first obtaining leave of the Council throughout 3 consecutive ordinary meetings of the Council is disqualified from continuing his or her membership of the Council.
- (5) The non-attendance of a member at the time and place appointed for an ordinary meeting of the Council does not constitute absence from an ordinary meeting of Council –
 - (a) if no meeting of the Council at which a quorum is present is actually held on that day; or
 - (b) if the non-attendance occurs while –
 - (i) the member has ceased to act as a member after which written notice has been given to the member under Section 2.27 (3) and before written notice has been given to the member under Section 2.27 (5);
 - (ii) while proceedings in connection with the disqualification of the member have been commenced and are pending; or
 - (iii) while the election of the member is disputed and proceedings relating to the disputed election have been commenced and are pending.

I,, hereby apply for Leave of Absence from the
 Ravensthorpe Shire Council from..... to for the
 purpose of

Signed:..... Date:.....



**Shire of Ravensthorpe
Notice of Ordinary Council Meetings**

In accordance with the Local Government Act 1995 and Administration Regulation 12 (I) it, is hereby notified that as from January 2019 to December 2019, Ordinary Council meetings of the Shire of Ravensthorpe will be held as follows:

| DATE | | LOCATION | TIME |
|--------------------------|--|--------------------------------------|-------------|
| January 2019 | No meetings Scheduled | | |
| 18 February 2019 | Council Forum | Ravensthorpe Council Chambers | 1pm |
| 21 February 2019 | Council Meeting | Ravensthorpe Council Chambers | 5pm |
| 18 March 2019 | Council Forum | Ravensthorpe Council Chambers | 1pm |
| 21 March 2019 | Council Meeting | Munglinup Community Centre | 5pm |
| 15 April 2019 | Council Forum | Ravensthorpe Council Chambers | 1pm |
| 18 April 2019 | Council Meeting | Hopetoun Community Centre | 5pm |
| 14 May 2019 | Council Meeting | Ravensthorpe Council Chambers | 6pm |
| 18 June 2019 | Council Meeting | Hopetoun Community Centre | 6pm |
| 16 July 2019 | Council Meeting | Ravensthorpe Council Chambers | 6pm |
| 20 August 2019 | Council Meeting | Hopetoun Community Centre | 6pm |
| 17 September 2019 | Council Meeting | Hopetoun Community Centre | 6pm |
| 15 October 2019 | Council Meeting | Ravensthorpe Council Chambers | 6pm |
| 21 October 2019 | Special Council Meeting – Elections | Ravensthorpe Council Chambers | 6pm |
| 19 November 2019 | Council Meeting | Hopetoun Community Centre | 6pm |
| 17 December 2019 | Council Meeting | Ravensthorpe Council Chambers | 6pm |

Ratepayers and residents are welcome to attend the council meetings and participate in the Public Question time session which are held at the beginning of each Council Meeting.

**Gavin Pollock
Chief Executive Officer**

ORDINARY MEETING OF COUNCIL
TO BE HELD IN THE COUNCIL CHAMBERS, RAVENSTHORPE
ON 14 MAY 2019, COMMENCING AT 6PM

| CONTENTS | PAGE |
|--|-------------|
| 1. DECLARATION OF OPENING / ANNOUNCEMENT OF VISITORS | 10 |
| 2. ATTENDANCE / APOLOGIES/ APPROVED LEAVE OF ABSENCE | 10 |
| 3. RESPONSE TO PREVIOUS QUESTIONS TAKEN ON NOTICE | 10 |
| 4. PUBLIC QUESTION TIME | 10 |
| 5. APPLICATIONS FOR, AND PREVIOUSLY APPROVED, LEAVE OF ABSENCE AND DISCLOSURES OF INTEREST . | 10 |
| 6. PETITIONS/ DEPUTATIONS/ PRESENTATIONS..... | 10 |
| 7. CONFIRMATION OF MINUTES..... | 10 |
| 7.1 COUNCIL MEETING – 15 APRIL 2019 AND 18 APRIL 2019..... | 10 |
| 8. SUSPENSION OF STANDING ORDERS..... | 11 |
| 9. ANNOUNCEMENT BY PRESIDING MEMBER WITHOUT DISCUSSIONS..... | 11 |
| 10. REPORTS OF OFFICERS..... | 12 |
| 10.1 DIRECTOR OF CORPORATE AND COMMUNITY SERVICES | 12 |
| 10.1.1 SCHEDULE OF ACCOUNT PAYMENTS – APRIL 2019 | 12 |
| 10.1.2 MONTHLY FINANCIAL REPORT –30 APRIL 2019..... | 15 |
| 10.2 MANAGER OF PLANNING AND DEVELOPMENT..... | 17 |
| 10.2.1 PROPOSED SIGNAGE (LOLLIPOP) LOT 806 MORGANS STREET, RAVENSTHORPE | 17 |
| 10.3 DIRECTOR OF TECHNICAL SERVICES | 25 |
| 10.4 CHIEF EXECUTIVE OFFICER | 26 |
| 11. ELECTED MEMBERS MOTIONS OF WHICH PREVIOUS NOTICE HAS BEEN GIVEN..... | 27 |
| 12. BUSINESS OF AN URGENT NATURE INTRODUCED BY DECISION OF MEETING | 27 |
| 12.1 ELECTED MEMBERS | 27 |
| 12.2 OFFICERS | 27 |
| 13. MATTERS BEHIND CLOSED DOORS | 27 |
| 14. CLOSURE OF MEETING..... | 27 |

THIS PAGE LEFT BLANK INTENTIONALLY

1. DECLARATION OF OPENING / ANNOUNCEMENT OF VISITORS

2. ATTENDANCE / APOLOGIES/ APPROVED LEAVE OF ABSENCE

MEMBERS: Cr Keith Dunlop (Shire President)
 Cr Julianne Belli (Deputy Shire President)
 Cr Kerry Dickinson
 Cr Thomas Major
 Cr Graham Richardson
 Cr Peter Smith

STAFF: Gavin Pollock (Chief Executive Officer)
 Les Mainwaring (Director of Corporate and Community Services)
 Graham Steel (Director Technical Services)
 Helen Coleman (Executive Assistant)

APOLOGIES:

ON LEAVE OF ABSENCE:
 Cr Ian Goldfinch

ABSENT:

3. RESPONSE TO PREVIOUS QUESTIONS TAKEN ON NOTICE

4. PUBLIC QUESTION TIME

5. APPLICATIONS FOR, AND PREVIOUSLY APPROVED, LEAVE OF ABSENCE AND DISCLOSURES OF INTEREST

6. PETITIONS/ DEPUTATIONS/ PRESENTATIONS

7. CONFIRMATION OF MINUTES

7.1 COUNCIL MEETING – 15 APRIL 2019 AND 18 APRIL 2019

| | |
|--|----------|
| OFFICER RECOMMENDATION | ITEM 7.1 |
| That the minutes of the meeting of council held on 15 April 2019 and 18 April 2019 be confirmed as a true and correct record of proceedings. | |

8. SUSPENSION OF STANDING ORDERS

OFFICER RECOMMENDATION

ITEM 8

That all Standing Orders be suspended for the remainder of the agenda items to enable detailed discussion, Councillors' questions and briefing by staff on the agenda items in accordance with Council's policy that the meeting on the third Monday of each month is a briefing/discussion meeting only and no decisions will be made on agenda items at this meeting. Decisions on the agenda items listed will be made at the meeting on the following Thursday.

9. ANNOUNCEMENT BY PRESIDING MEMBER WITHOUT DISCUSSIONS

10. REPORTS OF OFFICERS**10.1 DIRECTOR OF CORPORATE AND COMMUNITY SERVICES****10.1.1 SCHEDULE OF ACCOUNT PAYMENTS – APRIL 2019**

File Reference: GR.ME.8
Location: Shire of Ravensthorpe - Administration
Applicant: Internal
Author: Helen Coleman – Executive Assistant
Authorising Officer: Les Mainwaring – Director of Corporate and Community Services
Date: 3 May 2019
Disclosure of Interest: Nil
Attachments: 10.1.1.1 Schedule of Payments to 31 March 2019
 10.1.1.2 Credit Card Transactions to 30 April 2019
Previous Reference: Nil
Summary:

This item presents the schedule of payments for Council approval in accordance with Regulation 13 of the Local Government (Financial Management) Regulations 1996.

Background:

Period 1/7/2018 – 30/4/2019

2018/19

| Month | Cheques | EFT Pymts | Direct Debits | Credit Card | Trust | Total Creditors | Payroll |
|--------------|----------------|-------------------|------------------|---------------|----------------|-------------------|------------------|
| Jul | 1,367 | 2,442,344 | 90,290 | 12,115 | 950 | | 174,327 |
| Aug | 37,082 | 2,032,888 | 225,672 | 5,618 | 688 | 2,301,948 | 212,428 |
| Sep | 10,479 | 887,060 | 53,711 | 5,559 | 2,617 | 959,426 | 173,926 |
| Oct | 10,076 | 1,922,570 | 115,844 | 8,636 | 2,049 | 2,059,175 | 123,007 |
| Nov | 13,107 | 1,535,900 | 83,928 | 6,003 | 1,815 | 1,640,752 | 161,814 |
| Dec | 4,095 | 1,420,883 | 97,019 | | 833 | 1,522,831 | 238,074 |
| Jan | 11,899 | 493,318 | 48,486 | 4,145 | 580 | 558,427 | 171,237 |
| Feb | 9,940 | 886,889 | 211,726 | 2,817 | 540 | 1,111,912 | 184,652 |
| Mar | 1,155 | 2,560,559 | 106,713 | 2,185 | 1,350 | 2,671,962 | 251,635 |
| Apr | 1,599 | 2,112,538 | 123,583 | 3,438 | 530 | 2,241,688 | 172,442.55 |
| May | | | | | | 0 | |
| Jun | | | | | | 0 | |
| Total | 100,800 | 16,294,947 | 1,156,973 | 50,515 | 11,952 | 17,615,187 | 1,863,543 |
| 17/18 | 327,905 | 18,507,404 | 209,587 | 65,010 | 317,445 | 19,427,351 | 2,601,283 |

Comment:

This schedule of accounts as presented, submitted to each member of the Council, has been checked and is fully supported by vouchers and invoices which are submitted herewith and which have been duly certified as to the receipt of goods and the rendition of services and as to prices computation, and costing's and the amounts shown have been paid.

Consultation:

Bev Webb – Consultant Finance Officer.

Statutory Environment:

Regulation 13 (1) – (3) of the *Local Government (Financial Management) Regulations*

Policy Implications: N/A

Financial Implications: This item address Council’s expenditure from Trust and Municipal funds which have been paid under delegated authority.

Strategic Implications: N/A

Sustainability Implications:

- **Environmental:**
There are no known significant environmental considerations.
- **Economic:**
There are no known significant economic considerations.
- **Social:**
There are no known significant social considerations.

Risk Implications:

| | |
|---|---------|
| Risk | Low (2) |
| Risk Likelihood (based on history and with existing controls) | Low (2) |
| Risk Impact / Consequence | Low (2) |
| Risk Rating (Prior to Treatment or Control) | Low (2) |
| Principal Risk Theme | Low (2) |
| Risk Action Plan (Controls or Treatment Proposed) | Low (2) |

Risk Matrix

| Consequence Likelihood | | Insignificant | Minor | Moderate | Major | Catastrophic |
|------------------------|---|---------------|------------|------------|--------------|--------------|
| | | 1 | 2 | 3 | 4 | 5 |
| Almost Certain | 5 | Medium (5) | High (10) | High (15) | Extreme (20) | Extreme (25) |
| Likely | 4 | Low (4) | Medium (8) | High (12) | High (16) | Extreme (20) |
| Possible | 3 | Low (3) | Medium (6) | Medium (9) | High (12) | High (15) |
| Unlikely | 2 | Low (2) | Low (4) | Medium (6) | Medium (8) | High (10) |
| Rare | 1 | Low (1) | Low (2) | Low (3) | Low (4) | Medium (5) |

A risk is often specified in terms of an event or circumstance and the consequences that may flow from it. An effect may be positive, negative or a deviation from the expected and may be related to the following objectives; occupational health and safety, financial, service interruption, compliance, reputation and environment. A risk matrix has been prepared and a risk rating of 1

has been determined for this item. Any items with a risk rating over 10 (considered to be high or extreme risk) will be added to the Risk Register, and any item with a risk rating over 17 will require a specific risk treatment plan to be developed.

Voting Requirements: Simple Majority

Recommendation:

That pursuant to Regulation 13 of the *Local Government (Financial Management) Regulations 1996*, the payment of accounts for the month of April 2019 be noted.

That Council endorse;

Moved: _____

Seconded: _____

THIS PAGE LEFT BLANK INTENTIONALLY

Date: 03/05/2019
Time: 2:46:34PM

Shire of Ravensthorpe
Creditor payments April 2019

10.1.1.1 ATTACHMENT

USER: Wendy Spaans
PAGE: 1

| Cheque /EFT No | Date | Name | Invoice Description | Bank Code | INV Amount | Amount |
|----------------|------------|------------------------------------|--|-----------|------------|-----------|
| 46 | 16/04/2019 | Anthea Francis | REFUND FOR POOL KEY BOND | 2 | | 20.00 |
| 357 | 05/04/2019 | Telstra | SMS Desktop 25 Mar to 24 Apr 2019 | 1 | | 638.84 |
| 358 | 05/04/2019 | Water Corporation | Trade waste charges 5/3/19 to 30/6/19 | 1 | | 260.56 |
| 359 | 26/04/2019 | Ken Atkinson | Gratuitous Payment as per Policy | 1 | | 700.00 |
| EFT9904 | 05/04/2019 | AMPAC Debt Recovery | Commissions and costs for the month of March 2019 | 1 | | 286.00 |
| EFT9905 | 05/04/2019 | Bob Waddell & Associates Pty Ltd | Labour hire - Bev Webb | 1 | | 6,465.80 |
| EFT9906 | 05/04/2019 | Cocanarup Bush Fire Brigade | Reimbursement for Post office box | 1 | | 58.00 |
| | | | | | | |
| | | | | | | |
| | | | | | | |
| | | | | | | |
| | | | | | | |
| | | | | | | |
| | | | | | | |
| | | | | | | |
| | | | | | | |
| EFT9914 | 05/04/2019 | Cutting Edges Equipment Parts | Grader Blades | 1 | | 4,400.00 |
| EFT9915 | 05/04/2019 | Freight Lines Group | Freight charges - Westbuild P/O 19356 | 1 | | 274.14 |
| EFT9916 | 05/04/2019 | Hopetoun Community Resource Centre | Library Funding 18/19 | 1 | | 60,500.00 |
| EFT9917 | 05/04/2019 | Hopetoun Men In Sheds Incorporated | Manning of Hopetoun Transfer Station for February 2019 | 1 | | 1,000.00 |

Date: 03/05/2019
Time: 2:46:34PM

Shire of Ravensthorpe
Creditor payments April 2019

10.1.1.1 ATTACHMENT
USER: Wendy Spinks
PAGE: 2

| Cheque /EFT No | Date | Name | Invoice Description | Bank Code | INV Amount | Amount |
|-----------------------|-------------|---|---|------------------|-------------------|---------------|
| EFT9918 | 05/04/2019 | Hopetoun Refridgeration & Airconditioning | Diagnostics for Airconditioners, Travel | 1 | | 374.00 |
| EFT9919 | 05/04/2019 | Jerramungup Electrical Service (New) | Install Power point and Data point | 1 | | 354.70 |
| EFT9920 | 05/04/2019 | Kleenwest Distributors | Toilet rolls, Hand towels, Bin liners, Sparkle Boronia, Urinal blocks | 1 | | 2,579.83 |
| EFT9921 | 05/04/2019 | Landgate | Land enquiry x 23 for March 2019 | 1 | | 102.80 |
| EFT9922 | 05/04/2019 | Market Force | Advertisement - Professional Appointments | 1 | | 4,755.56 |
| EFT9923 | 05/04/2019 | MedTech Healthcare | Monthly site support for the month of March 2019 | 1 | | 110.00 |
| EFT9924 | 05/04/2019 | Munglinup Roadhouse | Cleaning ablution block | 1 | | 1,496.00 |
| EFT9925 | 05/04/2019 | Ravensthorpe Historical Society Inc. | FCTA Quarterly Rent for Museum | 1 | | 750.00 |
| EFT9926 | 05/04/2019 | Roselea Trading | Hopetoun Gym Rent | 1 | | 638.45 |
| EFT9927 | 05/04/2019 | Seek Limited | Seek advertisement Director of Corporate and Community Services | 1 | | 412.50 |
| EFT9928 | 05/04/2019 | Westbuild Products Pty Ltd | Asphalt repair cold mix 20kg x64 | 1 | | 571.65 |
| EFT9929 | 11/04/2019 | BCP Contractors Pty Ltd | WANDRRA AGRN 743 - Claim 5, Item 9 | 1 | | 708,785.91 |
| EFT9930 | 12/04/2019 | BOC Limited | Bottle rental -26/2/19 to 28/3/19 | 1 | | 35.99 |
| EFT9931 | 12/04/2019 | Bob Waddell & Associates Pty Ltd | Labour hire - Bev Webb, Assistance with annual budget | 1 | | 5,181.00 |
| EFT9932 | 12/04/2019 | CJD Equipment | Kit-brake shoe P/O194712 | 1 | | 2,783.88 |
| EFT9933 | 12/04/2019 | Caltex Australia Starcard | Fuel account for March 2019 | 1 | | 404.00 |
| EFT9934 | 12/04/2019 | Caltex Energy WA | Diesel 13,702L | 1 | | 18,851.45 |
| EFT9935 | 12/04/2019 | ChemCentre | Sample of treated effluent | 1 | | 259.60 |

Date: 03/05/2019
Time: 2:46:34PM

Shire of Ravensthorpe
Creditor payments April 2019

10.1.1.1 ATTACHMENT
USER: Wendy Spinks
PAGE: 3

| Cheque /EFT No | Date | Name | Invoice Description | Bank Code | INV Amount | Amount |
|----------------|------------|--------------------------------------|---|-----------|------------|------------|
| EFT9936 | 12/04/2019 | City of Albany | EHO resource sharing 27/2/19 to 25/3/19 | 1 | | 6,365.85 |
| EFT9937 | 12/04/2019 | Cleanaway Pty Ltd | Collections for March 2019 | 1 | | 17,454.41 |
| EFT9938 | 12/04/2019 | Commonwealth Bank | Monthly ATM Cash Servicing and Maintenance - 25/3/19 | 1 | | 1,835.38 |
| EFT9939 | 12/04/2019 | Cosimo Cutri | CONSULTANCY & LABOUR HIRE TO ASSIST WITH OPERATIONAL IMPROVEMENTS | 1 | | 3,780.00 |
| EFT9940 | 12/04/2019 | Courier Australia | Freight charges - Cutting edge | 1 | | 1,331.96 |
| EFT9941 | 12/04/2019 | Farmers Center Pty Ltd | Bulkhead, Quick fill | 1 | | 100.59 |
| EFT9942 | 12/04/2019 | Freight Lines Group | Freight charges - Kleenwest | 1 | | 243.08 |
| EFT9943 | 12/04/2019 | Helen Coleman | Reimbursement for National Police Certificate | 1 | | 54.30 |
| EFT9944 | 12/04/2019 | IT Vision Australia | RVN Rates services Jan to June 2019 | 1 | | 6,462.50 |
| EFT9945 | 12/04/2019 | JR & A Hersey Pty Ltd | Return of boots fee | 1 | | 20.00 |
| EFT9946 | 12/04/2019 | Jason Signmakers | Uni-Directional Chevron, White class roll | 1 | | 252.07 |
| EFT9947 | 12/04/2019 | Jerramungup Electrical Service (New) | New power and Data points | 1 | | 1,386.46 |
| EFT9948 | 12/04/2019 | Kleenwest Distributors | Toilet tissue, Hand towels, Bin liners, Neutra kleen, Sparkle noronia, Urinal blocks, Mop, Broom, Wipes | 1 | | 873.62 |
| EFT9949 | 12/04/2019 | Komatsu Australia PTY LTD | New Komatsu GD655_5, Motor Grader | 1 | | 370,700.00 |
| EFT9950 | 12/04/2019 | Lawry's Electrical Solutions | Disconnect and remove light towers | 1 | | 3,179.00 |
| EFT9951 | 12/04/2019 | Market Force | Advertisement - Professional Appointments - DCCS | 1 | | 9,519.02 |
| EFT9952 | 12/04/2019 | Moore Stephens Pty Ltd | Webinar training - Eimear Guidera, Heidi Bridger | 1 | | 770.00 |
| EFT9953 | 12/04/2019 | Perfect Computer Solutions | HP i7 Computer | 1 | | 3,285.00 |

Date: 03/05/2019
Time: 2:46:34PM

Shire of Ravensthorpe
Creditor payments April 2019

10.1.1.1 ATTACHMENT
USER: Wendy Spaans
PAGE: 4

| Cheque /EFT No | Date | Name | Invoice Description | Bank Code | INV Amount | Amount |
|----------------|------------|---|--|-----------|------------|------------|
| EFT9954 | 12/04/2019 | Ravensthorpe Cellars | Refreshments Council Chambers | 1 | | 168.00 |
| EFT9955 | 12/04/2019 | Ravensthorpe Community Resource Centre | Library funding 2018/19 - 4th Quarterly payment | 1 | | 13,721.40 |
| EFT9956 | 12/04/2019 | Ravensthorpe Quarry Services | Cracka Dust 23.87 Tonne | 1 | | 472.63 |
| EFT9957 | 12/04/2019 | Recharge-IT | Ink Cartridges | 1 | | 135.00 |
| EFT9958 | 12/04/2019 | Regal Panelbeaters | Excess on insurance repairs | 1 | | 500.00 |
| EFT9959 | 12/04/2019 | Shire of Gnowangerup | Training - Introduction to Local Government Workshop - Helen Coleman, Wendy Spaans | 1 | | 462.00 |
| EFT9960 | 12/04/2019 | Shire of Ravensthorpe Social Club | Payroll deductions | 1 | | 75.00 |
| EFT9961 | 12/04/2019 | WesTrac | New Caterpillar 289D LRC Skid Loader | 1 | | 132,099.00 |
| EFT9962 | 15/04/2019 | BCP Contractors Pty Ltd | Contract 4/2018 - Hamersley Drive Culham Inlet (WANDRRA) Claim 5 | 1 | | 626,640.71 |
| EFT9963 | 16/04/2019 | Jason P Dickie | GYM KEY BOND REFUND | 2 | | 20.00 |
| EFT9964 | 16/04/2019 | South Coast Natural Resource Management (NRM) | REFUND FOR FACILITY HIRE | 2 | | 50.00 |
| EFT9965 | 26/04/2019 | Cosimo Cutri | Consultancy and labour hire to assist with Operational improvements | 1 | | 4,535.00 |
| EFT9966 | 26/04/2019 | Lawry's Electrical Solutions | Supply and install new HID lights & re-use towers for interim period | 1 | | 40,656.00 |
| EFT9967 | 29/04/2019 | Bob Waddell & Associates Pty Ltd | ASSISTANCE PROVIDED BY BEV WEBB | 1 | | 13,263.80 |
| EFT9968 | 30/04/2019 | Digvija Singh | REFUND OF GYM KEY BOND | 2 | | 20.00 |
| EFT9969 | 30/04/2019 | Hopetoun Senior Citizens | REFUND FOR BOND OF HALL HIRE | 2 | | 400.00 |
| EFT9970 | 30/04/2019 | Rachael Doney | REFUND FOR GYM KEY BOND | 2 | | 20.00 |
| 1022 | 01/04/2019 | 1 - BANK FEES | OBB RECORD FEE | 1 | | 9.65 |

Date: 03/05/2019
Time: 2:46:34PM

Shire of Ravensthorpe
Creditor payments April 2019

10.1.1.1 ATTACHMENT
USER: Wendy Spinks
PAGE: 5

| Cheque /EFT No | Date | Name | Invoice Description | Bank Code | INV Amount | Amount |
|----------------|------------|---|--------------------------------|-----------|------------|----------|
| 1022 | 01/04/2019 | 1 - BANK FEES | MAINTENANCE FEE | 1 | | 60.00 |
| 1022 | 01/04/2019 | 1 - BANK FEES | ELECTRONIC TRANSACTION FEE | 1 | | 4.00 |
| 1022 | 01/04/2019 | 1 - BANK FEES | BPAY CREDIT CARD MERCHANT FEE | 1 | | 4.72 |
| 1022 | 01/04/2019 | 1 - BANK FEES | BPAY TRANSACTION FEE | 1 | | 143.25 |
| 1022 | 30/04/2019 | 1 - BANK FEES | DEBIT INTEREST | 1 | | 0.33 |
| 1022 | 03/04/2019 | 1 - BANK FEES | CBA MERCHANT FEE | 1 | | 68.57 |
| 1022 | 03/04/2019 | 1 - BANK FEES | CBA MERCHANT FEE | 1 | | 116.02 |
| DD4661.1 | 08/04/2019 | Loyd D.G. & Sandra Collins Superfund | Superannuation contributions | 1 | | 87.74 |
| DD4661.2 | 08/04/2019 | FirstChoice Personal Super | Superannuation contributions | 1 | | 177.20 |
| DD4661.3 | 08/04/2019 | Hesta Superannuation | Payroll deductions | 1 | | 226.91 |
| DD4661.4 | 08/04/2019 | BUSSQ | Payroll deductions | 1 | | 453.96 |
| DD4661.5 | 08/04/2019 | WA Local Government Super Plan | Payroll deductions | 1 | | 8,191.73 |
| DD4661.6 | 08/04/2019 | Australian Superannuation (Formally Westscheme) | Superannuation contributions | 1 | | 2,741.74 |
| DD4661.7 | 08/04/2019 | Colonial First State | Superannuation contributions | 1 | | 389.14 |
| DD4661.8 | 08/04/2019 | BT Super For Life | Superannuation contributions | 1 | | 194.63 |
| DD4661.9 | 08/04/2019 | MLC Superannuation | Superannuation contributions | 1 | | 48.42 |
| DD4662.1 | 11/04/2019 | Department of Transport (Shire Licensing) | Plate change 1GLO394 TO RA3794 | 1 | | 62.25 |
| DD4686.1 | 22/04/2019 | WA Local Government Super Plan | Superannuation contributions | 1 | | 319.89 |

Date: 03/05/2019
Time: 2:46:34PM

Shire of Ravensthorpe
Creditor payments April 2019

10.1.1.1 ATTACHMENT
USER: Wendy Spinks
PAGE: 6

| Cheque /EFT No | Date | Name | Invoice Description | Bank Code | INV Amount | Amount |
|----------------|------------|---|---|-----------|------------|-----------|
| DD4687.1 | 22/04/2019 | Loyd D.G. & Sandra Collins Superfund | Superannuation contributions | 1 | | 84.91 |
| DD4687.2 | 22/04/2019 | FirstChoice Personal Super | Superannuation contributions | 1 | | 134.39 |
| DD4687.3 | 22/04/2019 | Hesta Superannuation | Payroll deductions | 1 | | 145.52 |
| DD4687.4 | 22/04/2019 | BUSSQ | Payroll deductions | 1 | | 453.96 |
| DD4687.5 | 22/04/2019 | WA Local Government Super Plan | Payroll deductions | 1 | | 8,543.48 |
| DD4687.6 | 22/04/2019 | Australian Superannuation (Formally Westscheme) | Superannuation contributions | 1 | | 2,830.62 |
| DD4687.7 | 22/04/2019 | Colonial First State | Superannuation contributions | 1 | | 389.14 |
| DD4687.8 | 22/04/2019 | BT Super For Life | Superannuation contributions | 1 | | 194.64 |
| DD4687.9 | 22/04/2019 | MLC Superannuation | Superannuation contributions | 1 | | 48.42 |
| DD4690.1 | 16/04/2019 | BANKWEST Corporate Mastercard | March 2019 Statement | 1 | | 3,437.87 |
| DD4701.1 | 30/04/2019 | Department of Transport (Shire Licensing) | DoT PAYMENT BY AUTHORITY APRIL 2019 | 1 | | 23,812.55 |
| DD4701.2 | 30/04/2019 | Synergy | ACCOUNT PAYMENT BY AUTHORITY APRIL 2019 | 1 | | 9,873.55 |
| DD4701.3 | 30/04/2019 | Horizon Power | ACCOUNT PAYMENT BY AUTHORITY APRIL 2019 | 1 | | 5,797.06 |
| DD4701.4 | 30/04/2019 | Water Corporation | ACCOUNT PAYMENT BY AUTHORITY APRIL 2019 | 1 | | 1,218.89 |
| DD4701.5 | 15/04/2019 | SG Fleet | LEASE RENTALS APRIL 2019 | 1 | | 13,509.04 |
| DD4701.6 | 15/04/2019 | Westnet Pty Ltd | ACCOUNT PAYMENT BY AUTHORITY APRIL 2019 | 1 | | 675.60 |
| DD4701.7 | 01/04/2019 | WA Treasury Corporation (WATC) | WATC LOAN REPAYMENT APRIL 2019 | 1 | | 40,840.65 |
| DD4661.10 | 08/04/2019 | AMP Super | Superannuation contributions | 1 | | 63.64 |
| DD4661.11 | 08/04/2019 | BT Super for Life | Superannuation contributions | 1 | | 662.86 |

Date: 03/05/2019
Time: 2:46:34PM

Shire of Ravensthorpe
Creditor payments April 2019

10.1.1.1 ATTACHMENT
USER: Wendy Spinks
PAGE: 7

| Cheque /EFT No | Date | Name | Invoice Description | Bank Code | INV Amount | Amount |
|---------------------------|-------------|--------------------|------------------------------|----------------------|-----------------------|---------------|
| DD4661.12 | 08/04/2019 | Care Super Pty Ltd | Superannuation contributions | 1 | | 156.66 |
| DD4687.10 | 22/04/2019 | AMP Super | Superannuation contributions | 1 | | 63.64 |
| DD4687.11 | 22/04/2019 | BT Super for Life | Superannuation contributions | 1 | | 662.86 |
| DD4687.12 | 22/04/2019 | Care Super Pty Ltd | Superannuation contributions | 1 | | 120.65 |

REPORT TOTALS

| Bank Code | Bank Name | TOTAL |
|------------------|------------------------|---------------------|
| 1 | Municipal Bank Account | 2,241,157.69 |
| 2 | Trust Bank Account | 530.00 |
| TOTAL | | 2,241,687.69 |

01 March 2018 - 31 March 2019

Business Credit Card - Gavin Pollock Bankwest

| Date | Payment to | Description | Amount | GST |
|------------|----------------------------------|---|--------|-------|
| 22/03/2019 | Hopetoun IGA - Hopetoun | BBQ - Hopetoun Depot | 43.56 | 3.96 |
| 22/03/2019 | Abco Products - Bentley | Vacuum cleaners - Admin office and Rec centre | 966.43 | 87.86 |
| 22/03/2019 | Post Ravensthorpe - Ravensthorpe | Super glue | 3.74 | 0.34 |
| 28/03/2019 | FE DAW & Sons - Ravensthorpe | Morning tea meeting - Bev Webb | 40.03 | 1.03 |
| 28/03/2019 | Regional Express - Mascot | Flight - Les Mainwaring | 389.24 | 35.39 |
| 29/03/2019 | Bankwest | Reward fee - Executive | 69.00 | |

| | | |
|--|-----------------|---------------|
| Total Purchases for I. Fitzgerald | 1,512.00 | 128.58 |
|--|-----------------|---------------|

Business Credit Card - Graham Steel Bankwest

| Date | Payment to | Description | Amount | GST |
|------------|-------------------------------------|--|--------|-------|
| 28/02/2019 | Sai Global Limited - NSW Sydney | Australian standard publications (PDF) | 139.59 | 12.69 |
| 28/02/2019 | Ed Dept Screening Unit - East Perth | Criminal history check - Charmaine Arnold | 46.00 | 4.18 |
| 8/03/2019 | International on the water - Ascot | Accommodation - Ranger training Beau Shepherd | 588.70 | 53.52 |
| 8/03/2019 | Bunnings - Albany | Grinder bench, Wire wheel - Ravensthorpe Depot | 238.60 | 21.69 |
| 10/03/2019 | Care for kids Inet - Balmain | Advertisement for Childcare educator | 66.00 | 6.00 |
| 15/03/2019 | International on the water - Ascot | Accommodation - Ranger training Beau Shepherd | 133.98 | 12.18 |

| | | |
|--|----------------|---------------|
| | 1212.87 | 110.26 |
|--|----------------|---------------|

Business Credit Card - Robert Jarvis Bankwest

| Date | Payment to | Description | Amount | GST |
|-----------|---|-----------------------------------|--------|------|
| 2/03/2019 | Brookton Roadhouse - Brookton | Fuel | 40.00 | 3.64 |
| 7/03/2019 | Esperance Chamber of Commerce - Esperance | Room hire - D. Kennedy Meeting | 60.00 | 5.45 |
| 7/03/2019 | Lenick - Esperance | Coffee & Cake - D.Kennedy Meeting | 20.50 | 1.86 |

| | | |
|--|---------------|--------------|
| | 120.50 | 10.95 |
|--|---------------|--------------|

Business Credit Card - Ashley Peczka Bankwest

| Date | Payment to | Description | Amount | GST |
|------------|---------------------------------------|---------------|--------|-------|
| 14/03/2019 | Jerramungup Motor Hotel - Jerramungup | Accommodation | 105.50 | 9.59 |
| 15/03/2019 | The Murray Hotel - West Perth | Accommodation | 347.00 | 31.55 |
| 26/03/2019 | Bremer Bay Resort - Bremer Bay | Accommodation | 140.00 | 12.73 |

| | | |
|--|---------------|--------------|
| | 592.50 | 53.87 |
|--|---------------|--------------|

| | | |
|-------|--------------------|------------------|
| Total | \$ 3,437.87 | \$ 303.66 |
|-------|--------------------|------------------|

10.1.2 MONTHLY FINANCIAL REPORT –30 APRIL 2019

| | |
|--------------------------------|---|
| File Reference: | GR.ME.8 |
| Location: | Shire of Ravensthorpe - Administration |
| Applicant: | Internal |
| Author: | Bev Webb – Consultant Finance Officer |
| Authorising Officer: | Les Mainwaring –Director of Corporate and Community Services |
| Date: | 3 May 2019 |
| Disclosure of Interest: | Nil |
| Attachments: | 10.1.2.1 – Monthly Financial Reports for April 2019 |
| Previous Reference: | Nil |

Summary:

In accordance with the *Local Government Financial Management Regulations (1996)*, Regulation 34, a local government is to prepare a monthly Statement of Financial Activity for approval by Council.

Background:

Council is requested to review the April 2019 Monthly Financial Reports.

Comment:

The April 2019 Monthly Financial Report is presented for review.

Consultation:

Chief Executive Officer.

Statutory Environment:

Section 6.4 of the Local Government Act 1995 and Regulation 34 of the Local Government (Financial Management) Regulations 1996 apply.

Policy Implications:

Nil.

Financial Implications:

All expenditure has been approved via adoption of the 2018/19 Annual Budget, or resulting from a Council Motion for a budget amendment.

Strategic Implications: Strategic Community Plan 2014 – 2024

Theme 4 – Civic Leadership: 4.2 High quality corporate governance, accountability & compliance.

Sustainability Implications:

- **Environmental:**
Not applicable to this specific recurring report

- **Economic:**
Not applicable to this specific recurring report

- **Social:**
Not applicable to this specific recurring report

Risk Implications:

| | |
|---|---------|
| Risk | Low (2) |
| Risk Likelihood (based on history and with existing controls) | Low (2) |
| Risk Impact / Consequence | Low (2) |
| Risk Rating (Prior to Treatment or Control) | Low (2) |
| Principal Risk Theme | Low (2) |
| Risk Action Plan (Controls or Treatment Proposed) | Low (2) |

Risk Matrix

| Consequence Likelihood | | Risk Matrix | | | | |
|------------------------|---|--------------------|------------|---------------|--------------|-------------------|
| | | Insignificant 1 | Minor 2 | Moderate 3 | Major 4 | Catastrophic 5 |
| Almost Certain | 5 | Medium (5) | High (10) | High (15) | Extreme (20) | Extreme (25) |
| Likely | 4 | Low (4) | Medium (8) | High (12) | High (16) | Extreme (20) |
| Possible | 3 | Low (3) | Medium (6) | Medium (9) | High (12) | High (15) |
| Unlikely | 2 | Low (2) | Low (4) | Medium (6) | Medium (8) | High (10) |
| Rare | 1 | Low (1) | Low (2) | Low (3) | Low (4) | Medium (5) |

A risk is often specified in terms of an event or circumstance and the consequences that may flow from it. An effect may be positive, negative or a deviation from the expected and may be related to the following objectives; occupational health and safety, financial, service interruption, compliance, reputation and environment. A risk matrix has been prepared and a risk rating of 1 has been determined for this item. Any items with a risk rating over 10 (considered to be high or extreme risk) will be added to the Risk Register, and any item with a risk rating over 17 will require a specific risk treatment plan to be developed.

Voting Requirements: Simple Majority

Recommendation:

That Council receive the April 2019 Monthly Financial Report as presented.

That Council endorse;

Moved: _____

Seconded: _____



SHIRE OF RAVENSTHORPE
MONTHLY STATEMENT OF FINANCIAL ACTIVITY
FOR THE PERIOD ENDED 30 APRIL 2019

TABLE OF CONTENTS

| | Page |
|--|-------------|
| Graphical Analysis | 2 to 3 |
| Statement of Financial Activity | 4 |
| Report on Significant Variances | 5 to 6 |
| Budget Amendments | 7 |
| Notes to and Forming Part of the Statement | |
| 1 Acquisition of Assets | 8 to 9 |
| 2 Disposal of Assets | 10 |
| 3 Information on Borrowings | 11 |
| 4 Reserves | 12 to 14 |
| 5 Net Current Assets | 15 |
| 6 Rating Information | 16 |
| 7 Trust Funds | 17 |
| 8 Operating Statement | 18 to 19 |
| 9 Statement of Financial Position | 20 |
| 10 Financial Ratios | 21 |
| 11 Building Maintenance Report | 22 to 23 |

Income and Expenditure Graphs to 30 April 2019

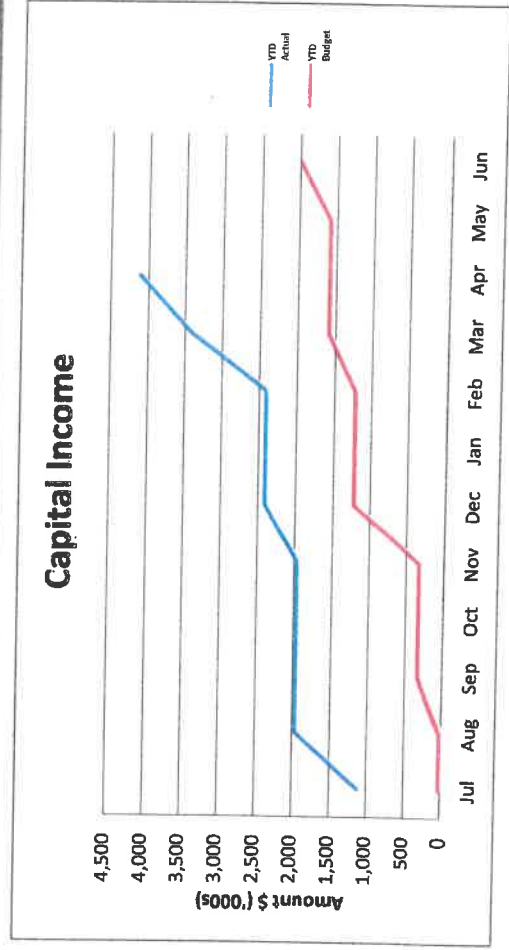
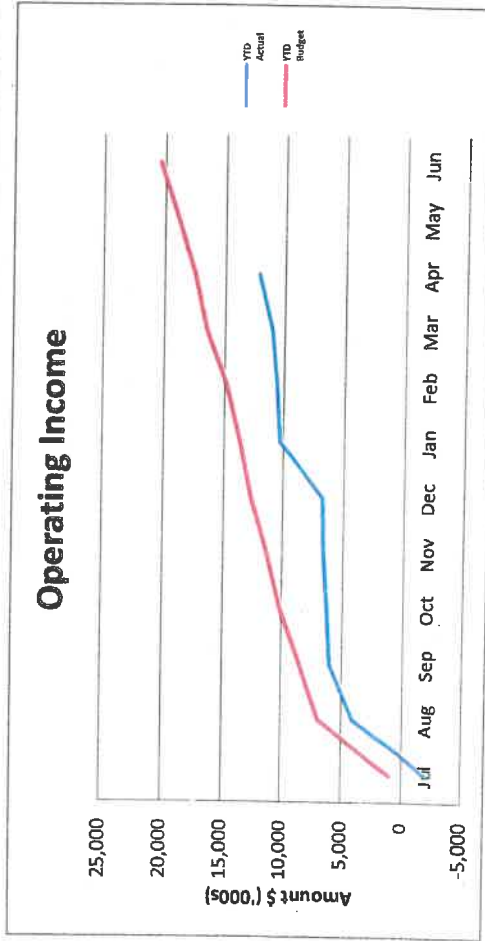
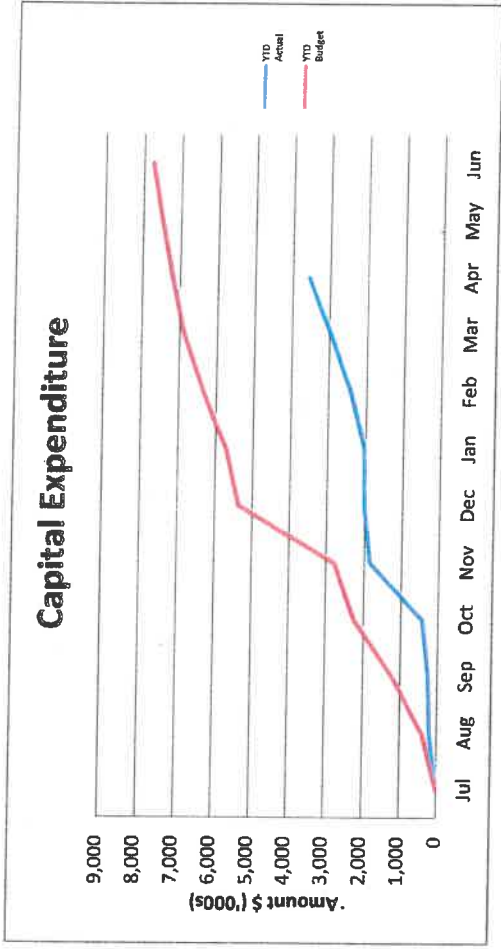
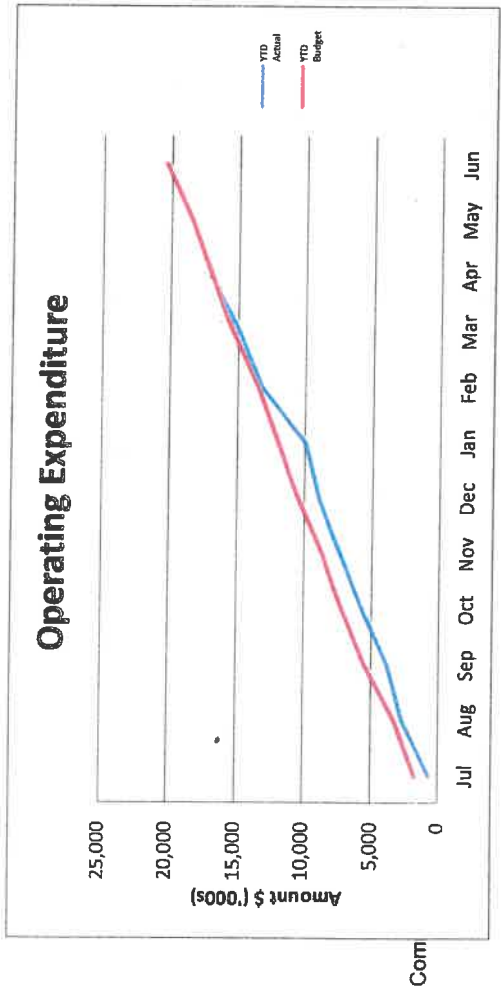

Other Graphs to 30 April 2019

Sundry Debtors Amount O/S

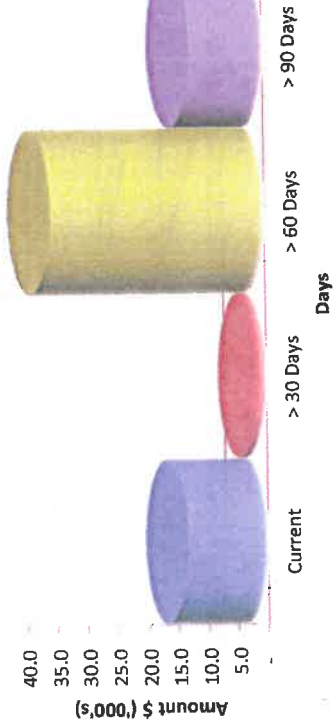

Rates % Collected

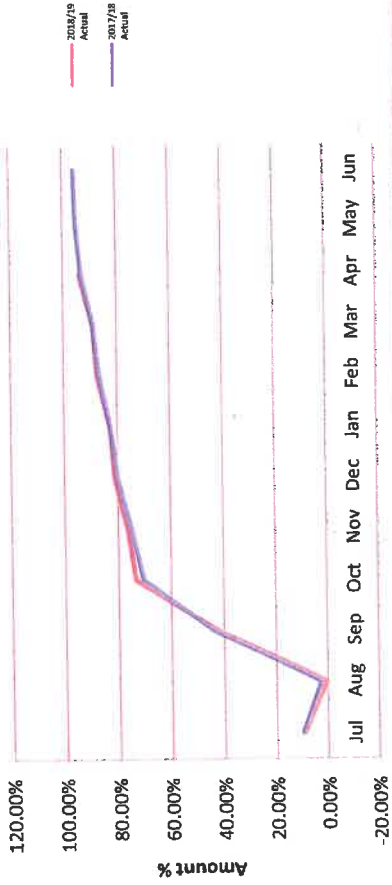

Capital Expenditure

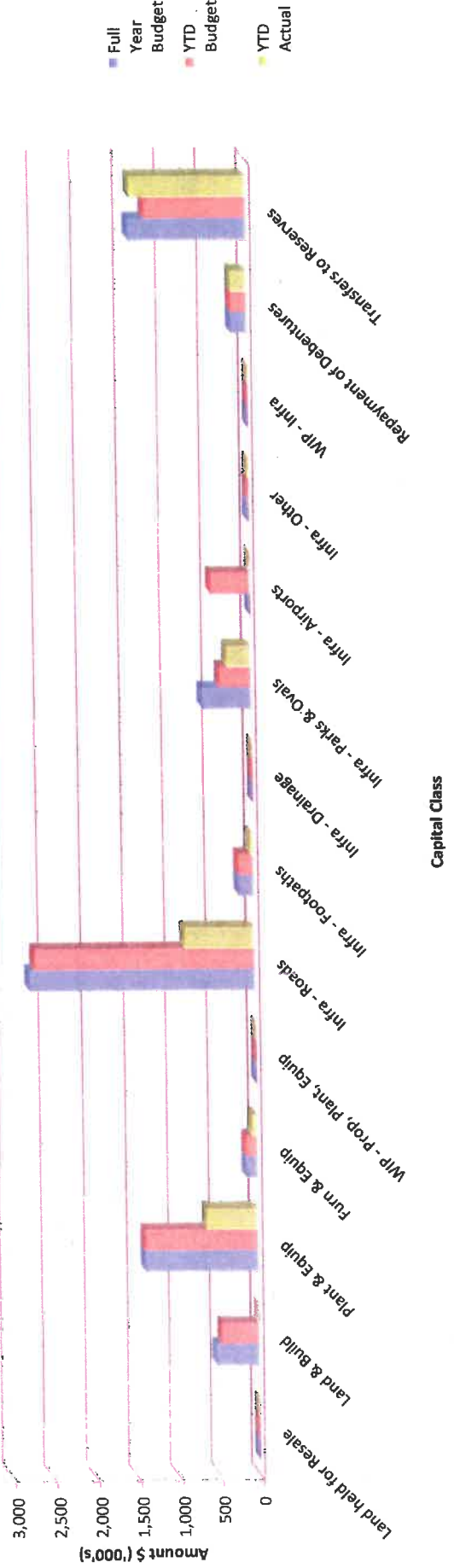

SHIRE OF RAVENSTHORPE
10.1.2.1 ATTACHMENT
STATEMENT OF FINANCIAL ACTIVITY

FOR THE PERIOD ENDED 30 APRIL 2019

| | NOTE | 2018/19 Adopted Budget \$ | 2018/19 Revised Budget \$ | APRIL 2019 Y-T-D Budget \$ | APRIL 2019 Actual \$ | Variances Actuals to Budget \$ | Variances Actual Budget to Y-T-D % |
|---|------|------------------------------------|------------------------------------|-------------------------------------|-------------------------------|---|--|
| Operating | | | | | | | |
| Revenues/Sources | | | | | | | |
| Governance | | 3,000 | 3,000 | 3,000 | 348 | (2,652) | (88.40%) |
| General Purpose Funding | | 1,080,200 | 1,080,200 | 839,695 | 838,629 | (1,066) | (0.13%) |
| Law, Order, Public Safety | | 225,190 | 225,190 | 193,950 | 308,766 | 114,816 | 59.20% |
| Health | | 3,000 | 3,000 | 2,493 | 4,829 | 2,336 | 93.70% |
| Education and Welfare | | 205,500 | 211,600 | 185,688 | 124,217 | (61,471) | (33.10%) |
| Housing | | 24,900 | 24,900 | 20,677 | 18,560 | (2,117) | (10.24%) |
| Community Amenities | | 699,097 | 699,097 | 623,602 | 464,926 | (158,676) | (25.45%) |
| Recreation and Culture | | 206,370 | 358,370 | 214,491 | 201,273 | (13,218) | (6.16%) |
| Transport | | 12,462,039 | 12,896,039 | 10,515,508 | 5,319,690 | (5,195,818) | (49.41%) |
| Economic Services | | 141,000 | 141,000 | 129,174 | 86,562 | (42,612) | (32.99%) |
| Other Property and Services | | 115,000 | 402,500 | 382,500 | 425,345 | 42,845 | 11.20% |
| | | <u>15,165,296</u> | <u>16,044,896</u> | <u>13,110,778</u> | <u>7,793,145</u> | <u>(5,317,633)</u> | <u>(40.56%)</u> |
| (Expenses)/(Applications) | | | | | | | |
| Governance | | (641,955) | (648,955) | (543,790) | (516,625) | 27,165 | 5.00% |
| General Purpose Funding | | (222,492) | (222,492) | (187,074) | (216,446) | (29,372) | (15.70%) |
| Law, Order, Public Safety | | (774,051) | (864,051) | (651,116) | (552,555) | 98,561 | 15.14% |
| Health | | (278,922) | (278,922) | (226,078) | (233,599) | (7,521) | (3.33%) |
| Education and Welfare | | (372,723) | (378,823) | (314,514) | (273,648) | 40,866 | 12.99% |
| Housing | | (258,313) | (219,340) | (186,231) | (187,536) | (1,305) | (0.70%) |
| Community Amenities | | (1,431,629) | (1,350,259) | (1,105,228) | (989,658) | 115,570 | 10.46% |
| Recreation & Culture | | (1,800,572) | (1,651,032) | (1,378,032) | (1,318,506) | 59,526 | 4.32% |
| Transport | | (13,686,930) | (13,686,930) | (11,395,934) | (11,343,844) | 52,090 | 0.46% |
| Economic Services | | (349,466) | (349,466) | (295,348) | (262,832) | 32,516 | 11.01% |
| Other Property and Services | | (341,600) | (591,600) | (574,165) | (1,064,073) | (489,908) | (85.33%) |
| | | <u>(20,158,653)</u> | <u>(20,241,869)</u> | <u>(16,857,510)</u> | <u>(16,959,322)</u> | <u>(101,812)</u> | <u>0.60%</u> |
| Net Operating Result Excluding Rates | | (4,993,357) | (4,196,973) | (3,746,732) | (9,166,177) | (5,419,445) | 144.64% |
| Adjustments for Non-Cash | | | | | | | |
| (Revenue) and Expenditure | | | | | | | |
| (Profit)/Loss on Asset Disposals | 2 | 131,000 | 131,000 | 110,500 | 30,720 | (79,780) | 72.20% |
| Movement in Deferred Pensioner Rates/ESL | | 0 | 0 | 0 | 0 | 0 | 0.00% |
| Movement in Employee Benefit Provisions | | (53,304) | (53,304) | 0 | (18,836) | (18,836) | 0.00% |
| Rounding | | 2 | 2 | 0 | 0 | 0 | 0.00% |
| Depreciation on Assets | | 3,302,576 | 3,302,576 | 2,752,128 | 2,485,832 | (286,296) | 9.68% |
| Capital Revenue and (Expenditure) | | | | | | | |
| Purchase of Land and Buildings | 1 | (11,020) | (528,103) | (460,090) | 0 | 460,090 | 100.00% |
| Purchase of Furniture & Equipment | 1 | (125,000) | (140,000) | (140,000) | (60,698) | 79,302 | 56.64% |
| Purchase of Plant & Equipment | 1 | (1,385,000) | (1,385,000) | (1,385,000) | (637,404) | 747,596 | 53.98% |
| Purchase of WIP - PP & E | 1 | 0 | 0 | 0 | 0 | 0 | 0.00% |
| Purchase of Infrastructure Assets - Roads | 1 | (2,716,716) | (2,716,716) | (2,655,678) | (866,084) | 1,789,594 | 67.39% |
| Purchase of Infrastructure Assets - Footpaths | 1 | (184,545) | (184,545) | (184,545) | (33,712) | 150,833 | 81.73% |
| Purchase of Infrastructure Assets - Drainage | 1 | 0 | 0 | 0 | 0 | 0 | 0.00% |
| Purchase of Infrastructure Assets - Parks & Ovals | 1 | (389,894) | (611,894) | (389,890) | (298,191) | 91,699 | 23.52% |
| Purchase of Infrastructure Assets - Airports | 1 | (492,000) | (492,000) | (492,000) | (43,422) | 448,578 | 91.17% |
| Purchase of Infrastructure Assets - Other | 1 | (16,000) | (16,000) | (16,000) | (10,197) | 5,803 | 36.27% |
| Proceeds from Disposal of Assets | 2 | 350,000 | 350,000 | 0 | 92,727 | 92,727 | 0.00% |
| Repayment of Debentures | 3 | (201,680) | (201,680) | (201,674) | (201,681) | (7) | (0.00%) |
| Transfers to Restricted Assets (Reserves) | 4 | (1,440,001) | (1,440,000) | (1,245,000) | (1,425,489) | (180,489) | (14.50%) |
| Transfers from Restricted Asset (Reserves) | 4 | 1,622,303 | 1,622,303 | 1,569,303 | 4,008,786 | 2,439,483 | 155.45% |
| Net Current Assets July 1 B/Fwd | 5 | 2,317,811 | 2,317,214 | 2,301,690 | 2,301,690 | 0 | 0.00% |
| Net Current Assets Year End/To date | 5 | (597) | 41,106 | 100,489 | 439,911 | 339,422 | (337.77%) |
| Amount Raised from Rates | | (4,284,228) | (4,284,228) | (4,283,477) | (4,282,047) | 1,430 | (0.03%) |

This statement is to be read in conjunction with the accompanying notes.

Material Variances Symbol

Above Budget Expectations Greater than 10% and \$100,000 ▲
Below Budget Expectations Less than 10% and \$100,000 ▼

Purpose

The purpose of the Monthly Variance Report is to highlight circumstances where there is a major variance from the YTD Monthly Budget and YTD Actual figures. These variances can occur because of a change in timing of the activity, circumstances change (e.g. a grants were budgeted for but was not received) or changes to the original budget projections. The Report is designed to highlight these issues and explain the reason for the variance.

The Materiality variance adopted by Council is:

Actual Variance exceeding 10% of YTD Budget or \$100,000 whichever is the lesser.

REPORTABLE OPERATING REVENUE VARIATIONS

General Purpose Funding - Revenue under YTD budget

TIMING - Reserve interest calculations to be updated

Governance - Revenue under YTD budget

PERMANENT - Income from seniors lunch overestimated

Law, Order, Public Safety - Revenue higher than YTD Budget

PERMANENT - Fire grants higher than budget estimates - contra to higher expenditure incurred

Education & Welfare - Revenue under YTD budget

TIMING - Further Cub House claims have not been raised

TIMING - Sustainability Grant due before June

Community Amenities - Revenue higher than YTD Budget

PERMANENT - Income relating to Sewerage over budget estimate

Community Amenities - Revenue under YTD budget

TIMING - Jerramungup Shire Landfill Recoups to be raised

Community Amenities - Revenue higher than YTD Budget

PERMANENT - Town Planning Scheme Income higher than budget estimate

Recreation & Culture - Revenue higher than YTD Budget

PERMANENT - Revenue for Public Halls higher than budget estimate

PERMANENT - Revenue for Swimming Pool higher than budget estimate

Recreation & Culture - Revenue under YTD budget

TIMING - Revenue for Other Rec and Sport

Transport - Revenue under YTD budget

TIMING - Flood damage and other Roads grants are to be received in future months.

TIMING - Income relating to Airport under budget estimate

TIMING - MRWA grant for MRF1 and MRF2 recoup for damage caused after flooding contra to exp

Transport - Revenue higher than YTD Budget

PERMANENT - MRWA Direct Grant over budget estimate

PERMANENT - R2R funds finalised

Economic Services - Revenue under YTD budget

TIMING - Revenue for other services (leases) to be reconciled

Other Property & Services - Revenue higher than YTD Budget

PERMANENT - Galaxy roadworks contra to expense

PERMANENT - Income relating to Administration higher than budget estimate

Other Property and Services - Revenue under YTD budget

PERMANENT - Diesel fuel rebate under budget estimate

REPORTABLE OPERATING EXPENSE VARIATIONS

Governance- Expenditure under YTD Budget

PERMANENT - CEO performance review not completed due to new CEO being appointed

TIMING - Integrated Planning

TIMING - Members expenses - Training, conferences etc

PERMANENT - Retention on insurance claim

General Purpose Funding- Expenditure under YTD Budget

PERMANENT - Rates and Legal Collection Expenses

TIMING - Valuation Expense due in June

PERMANENT - ATO interest on GST not reported in 2016/17

Law, Order, Public Safety - Expenditure under YTD Budget

TIMING: Brigade Management

TIMING - Ranger Services, Other expenses and SES Expenditure

Law, Order, Public Safety - Expenditure over YTD budget

PERMANENT - Bushfire Mitigation Activity over budget estimate but contra to income received

Health - Expenditure over YTD budget

TIMING - Doctors & Other Health budgeted expenditure and depreciation postings from unders & overs in this program.

Education & Welfare - Expenditure under YTD Budget

TIMING - Cub House expenditure under budget due to staffing issues

Housing - Expenditure under YTD Budget

TIMING - Building Maintenance under budget and depreciation not raised

Community Amenities - Expenditure under YTD Budget

PERMANENT - Regional Land fill operating costs under budget estimate

PERMANENT - Oil collection sites over budget estimates

TIMING - Effluent Scheme under budget estimate

Recreation & Culture - Expenditure under YTD Budget

TIMING - Maintenance costs Public Halls are lower than YTD budget.

TIMING - Hopetoun Resource Centre payment made in April

Transport - Expenditure under YTD Budget

PERMANENT - Metro counters will not be purchased this year

Transport - Expenditure over YTD budget

PERMANENT - Airport over budget estimate due to compliance audit

PERMANENT - Standpipe expenses are over budget estimates but contra to income over budget estimates

Economic Services - Expenditure under YTD Budget

TIMING - Dog and weed control under budget estimates

TIMING - Tourism and Area Promotion under budget estimates but contra to income which is also under budget estimates

PERMANENT - Building control expense under budget estimate - refer Albany contract

Economic Services - Expenditure over YTD budget

TIMING - Building Control over budget estimate

Other Property and Services - Expenditure over YTD budget

PERMANENT - Galaxy roadworks contra to income

TIMING - Public Works and Plant Operation Overheads allocations will be reconciled once depreciation has been raised

Other Property and Services - Expenditure under YTD Budget

TIMING - Expenses relating to demolition of property in Morgans street

REPORTABLE NON-CASH VARIATIONS

Depreciation on Assets - Expenditure under YTD budget

TIMING - Monthly depreciation has been journalled and has some variations. This will be rectified when 2017/18 financials completed

TIMING - Admin allocations will be reviewed and adjusted

REPORTABLE CAPITAL EXPENSE VARIATIONS

Purchase of Infrastructure Assets Roads - Expenditure under YTD budget

TIMING - Majority of capital upgrades to occur in 2019

Purchase of Infrastructure Assets Footpaths - Expenditure under YTD budget

TIMING - Majority of capital upgrades to occur in 2019

Purchase of Infrastructure Parks & Ovals - Expenditure under YTD budget

TIMING - Majority of capital upgrades to occur prior to 30 June

Purchase of Infrastructure Airports - Expenditure under YTD budget

TIMING - Majority of capital upgrades to occur in 2019

Purchase of Buildings - Expenditure under YTD budget

TIMING - 18 Carlisle, 93 Spence, Lot 79 Esplanade Hopetoun to be completed by June

TIMING - Ravensthorpe CRC kitchen improvements completed prior to 30 June

Repayment of Borrowings - Expenditure under YTD budget

TIMING - Repayment of some loans timing through creditors

Purchase of Plant & Equipment - Expenditure under YTD budget

TIMING - Major plant will be purchased in 4th quarter of financial year

Purchase of Furniture & Equipment - Expenditure under YTD budget

TIMING - Remaining furniture & equipment will be purchased in 4th quarter of financial year

REPORTABLE CAPITAL INCOME VARIATIONS

Transfers to/from Restricted Asset (Reserves) -

TIMING - Transfer to Reserves is reconciled in June

10.1.2.1 ATTACHMENT

BUDGET AMENDMENTS

Amendments to original budget since budget adoption. Surplus/(Deficit)

| Account# | Job# | Description | Council Res | Net Change | New Budget | Amended Budget Running Balance |
|---|--------|--|-------------|-----------------|------------|--------------------------------|
| 12201 | | 2018/19 Budget Estimated Surplus / (Deficit) | | | | -\$597 |
| 14522 | AL613 | Lot 177, Lot 318 & Lot 36 Floater Road - Gifted Income By Galaxy | 105/18 | \$434,000 | -\$434,000 | \$433,403 |
| 14101 | I141 | Lot 177, Lot 318 & Lot 36 Floater Road - (New Asset) | 105/18 | -\$434,000 | \$434,000 | -\$597 |
| 14100 | PW9 | Private Works Income - Stage 1 Temporary Road - Galaxy | 105/18 | \$287,500 | -\$287,500 | \$286,903 |
| 11301 | | Galaxy - Stage 1 Temporary Road Construction | 105/18 | -\$250,000 | \$250,000 | \$36,903 |
| 11301 | | From: Ravensthorpe Hopetoun Future Fund | 16/19 | -\$60,000 | | -\$23,097 |
| 11301 | | From: Tigers Football Club | 16/19 | -\$20,000 | | -\$43,097 |
| 11301 | | From: Shire of Ravensthorpe | 16/19 | -\$30,000 | | -\$73,097 |
| 11301 | | To: Ravensthorpe Hopetoun Future Fund | 16/19 | \$60,000 | | -\$13,097 |
| 11301 | | To: Ravensthorpe Tigers Football Club | 16/19 | \$10,000 | | -\$3,097 |
| 11301 | | To: Shire of Ravensthorpe | 16/19 | \$30,000 | | \$26,903 |
| 11301 | | To: Galaxy | 16/19 | \$20,000 | | \$46,903 |
| 11301 | | To: Lotterywest | 16/19 | \$125,000 | | \$171,903 |
| 11301 | | To: Ravensthorpe Tennis Club | 16/19 | \$2,000 | -\$137,000 | \$173,903 |
| 11315 | A1520 | Purchase Parks and Gardens Equipment | 16/19 | -\$137,000 | \$247,000 | \$36,903 |
| 11301 | AF622 | To: Gym Equipment Revenue Galaxy \$15,000 | 16/19 | 15,000 | -\$152,000 | \$51,903 |
| 08102 | CC002 | Gym Equipment | 16/19 | -\$15,000 | 45,000 | \$36,903 |
| 08107 | CH002 | From: Cub House Revenue | 16/19 | \$6,100 | -\$211,600 | \$43,003 |
| 04114 | | Toys for Cub House | 16/19 | -\$6,100 | \$18,250 | \$36,903 |
| 05303 | E155 | Audit Fee Expense | 24/19 | 7,000 | 37,000 | \$43,903 |
| 09101 | BM999 | Whale Removal and Disposal | 24/19 | 90,000 | 90,000 | \$133,903 |
| 09141 | AB583 | Reduced Maintenance to correctly reflect capital works | 24/19 | -\$38,973 | 35,000 | \$94,930 |
| 09141 | AB584 | New shed floor and relocation, kitchen improvements | 24/19 | 35,000 | 14,000 | \$129,930 |
| 09141 | AB585 | Landscaping and Kitchen improvements | 24/19 | 14,000 | 16,000 | \$143,930 |
| 10709 | BM/998 | Replace carpet, carpets, paint and repair back patio | 24/19 | 16,000 | 15,000 | \$159,930 |
| 11112 | BM/997 | Budget reduced to fund whale removal and disposal | 24/19 | -\$81,370 | 70,000 | \$78,560 |
| 11315 | AI526 | Reduced to fund capital housing improvements and Hopetoun Lighting Project | 24/19 | -\$162,740 | 85,000 | -\$84,180 |
| 11505 | AB606 | Remove existing lights and install new lights with required cabling and footings | 24/19 | 85,000 | 18,083 | \$820 |
| 11300 | B180 | Remove and replace ceilings that are falling down | 24/19 | 18,083 | 18,000 | \$36,903 |
| | | Youth programs and activities | 24/19 | 18,000 | | \$4,800 |
| | | Incorrect calculation in budget amendments council res 24/19 | | | | |
| Amended Budget as per Council Resolution (1) | | | | \$37,500 | | \$41,106 |

Amended Budget as per Council Resolution (1)

(1) Budget Surplus / (Deficit) position as per the Statement of Financial Activity

NOTES TO AND FORMING PART OF THE STATEMENT OF FINANCIAL ACTIVITY

FOR THE PERIOD ENDED 30 APRIL 2019

| 1. ACQUISITION OF ASSETS | 2018/19 Adopted Budget \$ | 2018/19 Revised Budget \$ | 2018/19 YTD Budget \$ | APRIL 2019 Actual \$ |
|---|------------------------------------|------------------------------------|--------------------------------|-------------------------------|
| The following assets have been acquired during the period under review: | | | | |
| <u>By Program</u> | | | | |
| Governance | | | | |
| <i>Members of Council</i> | | | | |
| Purchase Furniture & Equipment | 0 | 0 | 0 | 0 |
| Law, Order & Public Safety | | | | |
| <i>Fire Prevention & Control</i> | | | | |
| Water Tank 80,000Ltr - Jerdacuttup Bfb | 11,020 | 11,020 | 11,020 | 0 |
| Health | | | | |
| <i>Doctors & Other Health</i> | | | | |
| TIMING Edge Ii Ultrasound | 60,000 | 60,000 | 60,000 | 60,010 |
| Housing | | | | |
| <i>Staff Housing</i> | | | | |
| 18 Carlisle St Housing Upgrade | 0 | 35,000 | 0 | 0 |
| 93 Spence St Housing Upgrade | 0 | 14,000 | 0 | 0 |
| Lot 79 Esplanade Hopetoun Housing Upgrade | 0 | 16,000 | 0 | 0 |
| | 0 | 0 | 0 | 0 |
| <i>Other Housing</i> | | | | |
| Community Amenities | | | | |
| <i>Sanitation - Household Refuse</i> | | | | |
| Ravensthorpe Regional Landfill | 16,000 | 16,000 | 16,000 | 10,197 |
| Recreation and Culture | | | | |
| <i>Other Recreation & Sport</i> | | | | |
| New Gym Equipment | 30,000 | 45,000 | 45,000 | 0 |
| Hopetoun Tennis Courts Resurface | 30,024 | 30,024 | 30,024 | 30,024 |
| Rangeview Park Upgrade | 160,000 | 160,000 | 159,996 | 0 |
| Ravensthorpe Cricket Pitch | 7,000 | 7,000 | 7,000 | 0 |
| Ravensthorpe Tennis Courts | 43,870 | 43,870 | 43,870 | 43,870 |
| Ravensthorpe Bowls Club - Lighting | 39,000 | 39,000 | 39,000 | 37,203 |
| Playground Renewal - Ravensthorpe Rec | 110,000 | 247,000 | 110,000 | 150,794 |
| Hopetoun Upgrade Of Oval Lighting | 0 | 85,000 | 0 | 36,300 |
| <i>Libraries</i> | | | | |
| Ravensthorpe Crc - Kitchen Improvements | 0 | 18,083 | 15,070 | 0 |
| Transport | | | | |
| <i>Construction - Roads, Bridges, Depots</i> | | | | |
| Roads Construction Council | | | | |
| Four Mile Carpark - Construct New Parking | 30,000 | 30,000 | 30,000 | 0 |
| Queen Street - Infill Stormwater Drain Adjacent | 45,000 | 45,000 | 45,000 | 33,833 |
| Phillips River Rd Canoe Trail | 28,517 | 28,517 | 0 | 0 |
| Streetscape Morgan Street Stage 2 | 25,000 | 25,000 | 25,000 | 93,225 |
| Floodway Sealing Repairs | 50,310 | 50,310 | 50,310 | 994 |
| Veal Street - Carpark Expansion | 0 | 0 | 0 | 0 |
| Gravel Pit Reinstatement | 75,000 | 75,000 | 56,247 | 4,353 |
| Gravel Pit Development | 55,000 | 55,000 | 41,247 | 0 |
| Roads Mrwa V Of G Constr | | | | |
| Jerdacuttup Road - Stabilise Pavement & | 275,000 | 275,000 | 275,000 | 275,283 |
| Springdale Road - Bitumen Reseal (Rrg) | 135,000 | 135,000 | 135,000 | 0 |
| Hammersley Drive Bitumen Reseal (Rrg) | 135,000 | 135,000 | 135,000 | 0 |
| Mrwa Project Construction | | | | |
| Fitzgerald Rd - Gravel Re-Sheet Slk 43.3 - | 548,050 | 548,050 | 548,048 | 0 |
| Koornong Rd - Gravel Re-Sheet Slk 6.12 - | 752,348 | 752,348 | 752,341 | 0 |

10.1.2.1 ATTACHMENT

SHIRE OF RAVENSTHORPE

NOTES TO AND FORMING PART OF THE STATEMENT OF FINANCIAL ACTIVITY

FOR THE PERIOD ENDED 30 APRIL 2019

| 1. ACQUISITION OF ASSETS (Continued) | 2018/19 Adopted Budget \$ | 2018/19 Revised Budget \$ | 2018/19 YTD Budget \$ | APRIL 2019 Actual \$ |
|---|------------------------------------|------------------------------------|--------------------------------|-------------------------------|
| The following assets have been acquired during the period under review: | | | | |
| By Program (Continued) | | | | |
| Transport (Continued) | | | | |
| Roads To Recovery Construction | | | | |
| Ravensthorpe Streets | 462,491 | 462,491 | 462,485 | 456,015 |
| Neil & Spence St Intersection | 0 | 0 | 0 | 2,381 |
| Bridges Construction | | | | |
| Springdale Road Bridge | 100,000 | 100,000 | 100,000 | 0 |
| Footpath Construction | | | | |
| Chittick St/Gibson Way/Forrest Way - | 117,500 | 117,500 | 117,500 | 0 |
| Crc/Dunnart - Laneway Paving & Landscaping | 39,940 | 39,940 | 39,940 | 32,870 |
| Hosking Street - Concrete Footpath | 27,105 | 27,105 | 27,105 | 842 |
| Road Plant Purchases | | | | |
| Maintenance Grader Replacement | 330,000 | 330,000 | 330,000 | 337,000 |
| Multi Tyre Roller | 185,000 | 185,000 | 185,000 | 0 |
| Skid Steer Loader | 100,000 | 100,000 | 100,000 | 120,090 |
| Construction Loader | 310,000 | 310,000 | 310,000 | 0 |
| Light Truck - P&G Ravensthorpe | 60,000 | 60,000 | 60,000 | 0 |
| Side Tipper | 105,000 | 105,000 | 105,000 | 0 |
| Mechanical Workshop Fitout | 50,000 | 50,000 | 50,000 | 0 |
| Street Sweeper Trailer | 10,000 | 10,000 | 10,000 | 10,891 |
| Zero Turn Mower | 7,000 | 7,000 | 7,000 | 0 |
| Aerodromes | | | | |
| Runway Reseal | 492,000 | 492,000 | 492,000 | 43,422 |
| Other Property & Services | | | | |
| Administration | | | | |
| Computer Upgrades | 35,000 | 35,000 | 35,000 | 688 |
| Toyota Landcruiser/Prado - Ceo | 75,000 | 75,000 | 75,000 | 76,288 |
| Toyota Hilux Dual Cab - Mes | 60,000 | 60,000 | 60,000 | 50,447 |
| Toyota Fortuner - Mccs | 48,000 | 48,000 | 48,000 | 0 |
| Toyota Hilux Dual Cab (Pool Car) | 45,000 | 45,000 | 45,000 | 42,688 |
| Land Lot 36,318 & 177 Floater Road | 0 | 434,000 | 434,000 | 0 |
| | <u>5,320,175</u> | <u>6,074,258</u> | <u>5,723,203</u> | <u>1,949,708</u> |
| By Class | | | | |
| Land | 0 | 434,000 | 434,000 | 0 |
| Buildings | 11,020 | 94,103 | 26,090 | 0 |
| Furniture & Equipment | 125,000 | 140,000 | 140,000 | 60,698 |
| Plant & Equipment | 1,385,000 | 1,385,000 | 1,385,000 | 637,404 |
| Work in Progress - PPE | 0 | 0 | 0 | 0 |
| Infrastructure - Roads | 2,716,716 | 2,716,716 | 2,655,678 | 866,084 |
| Infrastructure - Footpaths | 184,545 | 184,545 | 184,545 | 33,712 |
| Infrastructure - Drainage | 0 | 0 | 0 | 0 |
| Infrastructure - Parks & Ovals | 389,894 | 611,894 | 389,890 | 298,191 |
| Infrastructure - Airports | 492,000 | 492,000 | 492,000 | 43,422 |
| Infrastructure - Other | 16,000 | 16,000 | 16,000 | 10,197 |
| Work in Progress - INFRA | 0 | 0 | 0 | 0 |
| | <u>5,320,175</u> | <u>6,074,258</u> | <u>5,723,203</u> | <u>1,949,708</u> |

NOTES TO AND FORMING PART OF THE STATEMENT OF FINANCIAL ACTIVITY

FOR THE PERIOD ENDED 30 APRIL 2019

2. DISPOSALS OF ASSETS

The following assets have been disposed of during the period under review:

| By Program | Written Down Value | | Sale Proceeds | | Profit(Loss) | |
|--------------------------------------|--|--|--|--|--|--|
| | 2018/19 Adopted Budget \$ | 2018/19 YTD Actual \$ | 2018/19 Adopted Budget \$ | 2018/19 YTD Actual \$ | 2018/19 Adopted Budget \$ | 2018/19 YTD Actual \$ |
| Transport | | | | | | |
| John Deere 670G 2012 Grader | 133,000.00 | | 80,000.00 | | (53,000.00) | 0.00 |
| Ammann AP240 Multi Tyre Roller | 25,000.00 | | 25,000.00 | | 0.00 | 0.00 |
| Bobcat & Attachments | 37,000.00 | | 20,000.00 | | (17,000.00) | 0.00 |
| John Deere 624K Z Bar Loader | 98,000.00 | | 80,000.00 | | (18,000.00) | 0.00 |
| Mitsubishi Triton | 10,000.00 | | 8,000.00 | | (2,000.00) | 0.00 |
| Mitsubishi Triton GLX Pool Car | 24,000.00 | 25,707.19 | 16,000.00 | 15,454.55 | (8,000.00) | (10,252.64) |
| Duraquip Side Tipper | 35,000.00 | | 10,000.00 | | (25,000.00) | 0.00 |
| Other Property & Services | | | | | | |
| Toyota Prado (CEO) | 52,000.00 | 52,175.09 | 50,000.00 | 42,727.27 | (2,000.00) | (9,447.82) |
| Toyota Hilux D/C (MES) | 46,000.00 | 45,564.57 | 40,000.00 | 34,545.45 | (6,000.00) | (11,019.12) |
| Toyota Kluger (MCCS) | 21,000.00 | | 21,000.00 | | 0.00 | 0.00 |
| | 481,000.00 | 123,446.85 | 350,000.00 | 92,727.27 | (131,000.00) | (30,719.58) |

By Class of Asset

| | Written Down Value | | Sale Proceeds | | Profit(Loss) | |
|--------------------------------|--|--|--|--|--|--|
| | 2018/19 Adopted Budget \$ | 2018/19 YTD Actual \$ | 2018/19 Adopted Budget \$ | 2018/19 YTD Actual \$ | 2018/19 Adopted Budget \$ | 2018/19 YTD Actual \$ |
| Plant & Equipment | | | | | | |
| John Deere 670G 2012 Grader | 133,000.00 | 0.00 | 80,000.00 | 0.00 | (53,000.00) | 0.00 |
| Ammann AP240 Multi Tyre Roller | 25,000.00 | 0.00 | 25,000.00 | 0.00 | 0.00 | 0.00 |
| Bobcat & Attachments | 37,000.00 | 0.00 | 20,000.00 | 0.00 | (17,000.00) | 0.00 |
| John Deere 624K Z Bar Loader | 98,000.00 | 0.00 | 80,000.00 | 0.00 | (18,000.00) | 0.00 |
| Mitsubishi Triton | 10,000.00 | 0.00 | 8,000.00 | 0.00 | (2,000.00) | 0.00 |
| Mitsubishi Triton GLX Pool Car | 24,000.00 | 25,707.19 | 16,000.00 | 15,454.55 | (8,000.00) | (10,252.64) |
| Duraquip Side Tipper | 35,000.00 | 0.00 | 10,000.00 | 0.00 | (25,000.00) | 0.00 |
| Toyota Prado (CEO) | 52,000.00 | 52,175.09 | 50,000.00 | 42,727.27 | (2,000.00) | (9,447.82) |
| Toyota Hilux D/C (MES) | 46,000.00 | 45,564.57 | 40,000.00 | 34,545.45 | (6,000.00) | (11,019.12) |
| Toyota Kluger (MCCS) | 21,000.00 | 0.00 | 21,000.00 | 0.00 | 0.00 | 0.00 |
| | 481,000.00 | 123,446.85 | 350,000.00 | 92,727.27 | (131,000) | (30,719.58) |

Summary

| | 2018/19 Adopted Budget \$ | 2018/19 YTD Actual \$ |
|---------------------------|--|--|
| Profit on Asset Disposals | | 0.00 |
| Loss on Asset Disposals | (131,000.00) | (30,719.58) |
| | <u>(131,000.00)</u> | <u>(30,719.58)</u> |

Vehicles have been traded, however transactions for Profit/Loss will be processed once the Annual Audit is complete

SHIRE OF RAVENSTHORPE

NOTES TO AND FORMING PART OF THE STATEMENT OF FINANCIAL ACTIVITY

FOR THE PERIOD ENDED 30 APRIL 2019

3. INFORMATION ON BORROWINGS

(a) Debenture Repayments

| Particulars | Principal 1-Jul-18 | Principal Repayments | | Principal Outstanding | | Interest Repayments | |
|------------------------------------|-----------------------|------------------------------------|--------------------------------|------------------------------------|--------------------------------|------------------------------------|--------------------------------|
| | | 2018/19 Adopted Budget \$ | 2018/19 YTD Actual \$ | 2018/19 Adopted Budget \$ | 2018/19 YTD Actual \$ | 2018/19 Adopted Budget \$ | 2018/19 YTD Actual \$ |
| Housing | | | | | | | |
| Loan 145 Staff Housing | 258,870 | 33,907 | 33,907 | 224,964 | 224,963 | 8,779 | 5,038 |
| Loan 147 Other Housing | 254,711 | 15,919 | 15,919 | 238,792 | 238,792 | 10,153 | 7,148 |
| Recreation and Culture | | | | | | | |
| Loan 146 Hopetoun Community Centre | 325,114 | 13,123 | 13,123 | 311,991 | 311,991 | 13,772 | 8,073 |
| Transport | | | | | | | |
| Loan 138D Town Street | 318,113 | 26,801 | 26,801 | 291,312 | 291,312 | 22,889 | 13,702 |
| Loan 144 Town Street | 205,645 | 47,682 | 47,682 | 157,962 | 157,963 | 11,005 | 7,797 |
| Loan 143B Refinance | 231,832 | 30,365 | 30,365 | 201,467 | 201,467 | 7,862 | 4,512 |
| Loan 138E Refinance | 301,765 | 33,884 | 33,884 | 267,881 | 267,881 | 10,820 | 6,277 |
| | 1,896,049 | 201,680 | 201,681 | 1,694,368 | 1,694,368 | 85,280 | 52,547 |

(*) Self supporting loan financed by payments from third parties.
All other loan repayments were financed by general purpose revenue.

NOTES TO AND FORMING PART OF THE STATEMENT OF FINANCIAL ACTIVITY

FOR THE PERIOD ENDED 30 APRIL 2019

| | 2018/19 Adopted Budget \$ | 2018/19 YTD Actual \$ |
|--|------------------------------------|--------------------------------|
| 4. RESERVES | | |
| Cash Backed Reserves | | |
| (a) Plant Reserve | | |
| Opening Balance | 430,959 | 430,959 |
| Amount Set Aside / Transfer to Reserve | 6,801 | 2,889 |
| Amount Used / Transfer from Reserve | <u>0</u> | <u>0</u> |
| | <u>437,760</u> | <u>433,848</u> |
| (b) Emergency Farm Water Reserve | | |
| Opening Balance | 26,734 | 26,734 |
| Amount Set Aside / Transfer to Reserve | 422 | 179 |
| Amount Used / Transfer from Reserve | <u>0</u> | <u>0</u> |
| | <u>27,156</u> | <u>26,913</u> |
| (c) Building Reserve | | |
| Opening Balance | 1,519,294 | 1,519,294 |
| Amount Set Aside / Transfer to Reserve | 1,223,977 | 1,410,186 |
| Amount Used / Transfer from Reserve | <u>(1,200,000)</u> | <u>(3,586,483)</u> |
| | <u>1,543,271</u> | <u>(657,003)</u> |
| (d) Road & Footpath Reserve | | |
| Opening Balance | 422,867 | 422,867 |
| Amount Set Aside / Transfer to Reserve | 6,673 | 2,726 |
| Amount Used / Transfer from Reserve | <u>0</u> | <u>0</u> |
| | <u>429,540</u> | <u>425,593</u> |
| (e) Swimming Pool Upgrade Reserve | | |
| Opening Balance | 44,031 | 44,031 |
| Amount Set Aside / Transfer to Reserve | 695 | 404 |
| Amount Used / Transfer from Reserve | <u>0</u> | <u>0</u> |
| | <u>44,726</u> | <u>44,435</u> |
| (f) UHF Repeater Reserve | | |
| Opening Balance | 0 | 0 |
| Amount Set Aside / Transfer to Reserve | 0 | 0 |
| Amount Used / Transfer from Reserve | <u>0</u> | <u>0</u> |
| | <u>0</u> | <u>0</u> |
| (g) Airport Reserve | | |
| Opening Balance | 751,528 | 751,528 |
| Amount Set Aside / Transfer to Reserve | 61,860 | 5,039 |
| Amount Used / Transfer from Reserve | <u>(369,303)</u> | <u>(369,303)</u> |
| | <u>444,085</u> | <u>387,264</u> |
| (h) Waste & Sewerage Reserve | | |
| Opening Balance | 298,032 | 298,032 |
| Amount Set Aside / Transfer to Reserve | 39,703 | 1,998 |
| Amount Used / Transfer from Reserve | <u>0</u> | <u>0</u> |
| | <u>337,735</u> | <u>300,030</u> |

NOTES TO AND FORMING PART OF THE STATEMENT OF FINANCIAL ACTIVITY

FOR THE PERIOD ENDED 30 APRIL 2019

| | 2018/19 Adopted Budget \$ | 2018/19 YTD Actual \$ |
|---|------------------------------------|--------------------------------|
| 4. RESERVES (Continued) | | |
| Cash Backed Reserves (Continued) | | |
| (i) State Barrier Fence Reserve | | |
| Opening Balance | 214,099 | 214,099 |
| Amount Set Aside / Transfer to Reserve | 73,379 | 1,435 |
| Amount Used / Transfer from Reserve | 0 | 0 |
| | <u>287,478</u> | <u>215,534</u> |
| (j) Leave Reserve | | |
| Opening Balance | 94,483 | 94,483 |
| Amount Set Aside / Transfer to Reserve | 26,491 | 633 |
| Amount Used / Transfer from Reserve | (53,000) | (53,000) |
| | <u>67,974</u> | <u>42,116</u> |
| Total Cash Backed Reserves | <u><u>3,619,725</u></u> | <u><u>1,218,730</u></u> |

All of the above reserve accounts are to be supported by money held in financial institutions.

**Summary of Transfers
To Cash Backed Reserves****Transfers to Reserves**

| | | |
|-------------------------------|------------------|------------------|
| Plant Reserve | 6,801 | 2,889 |
| Emergency Farm Water Reserve | 422 | 179 |
| Building Reserve | 1,223,977 | 1,410,186 |
| Road & Footpath Reserve | 6,673 | 2,726 |
| Swimming Pool Upgrade Reserve | 695 | 404 |
| UHF Repeater Reserve | 0 | 0 |
| Airport Reserve | 61,860 | 5,039 |
| Waste & Sewerage Reserve | 39,703 | 1,998 |
| State Barrier Fence Reserve | 73,379 | 1,435 |
| Leave Reserve | 26,491 | 633 |
| | <u>1,440,001</u> | <u>1,425,489</u> |

Transfers from Reserves

| | | |
|--|-------------------------|---------------------------|
| Plant Reserve | 0 | 0 |
| Emergency Farm Water Reserve | 0 | 0 |
| Building Reserve | (1,200,000) | (3,586,483) |
| Road & Footpath Reserve | 0 | 0 |
| Swimming Pool Upgrade Reserve | 0 | 0 |
| UHF Repeater Reserve | 0 | 0 |
| Airport Reserve | (369,303) | (369,303) |
| Waste & Sewerage Reserve | 0 | 0 |
| State Barrier Fence Reserve | 0 | 0 |
| Leave Reserve | (53,000) | (53,000) |
| | <u>(1,622,303)</u> | <u>(4,008,786)</u> |
| Total Transfer to/(from) Reserves | <u><u>(182,302)</u></u> | <u><u>(2,583,297)</u></u> |

NOTES TO AND FORMING PART OF THE STATEMENT OF FINANCIAL ACTIVITY

FOR THE PERIOD ENDED 30 APRIL 2019

4. RESERVES (Continued)

Cash Backed Reserves (Continued)

In accordance with council resolutions in relation to each reserve account, the purpose for which the reserves are set aside are as follows:

Plant Reserve

To be used to assist in the purchasing of major plant and machinery.

Emergency Farm Water Reserve

To be used for the repair and/or construction of emergency farm water supplies in the Shire of Ravensthorpe

Building Reserve

To be used for the construction, refurbishment, modification or renovation of all buildings in the Shire of Ravensthorpe

Road and Footpath Reserve

To be used for the construction, renewal, resealing or repair of the road and footpath network.

Swimming Pool Upgrade Reserve

To be used towards any major repairs or improvements for the Ravensthorpe swimming pool.

UHF Repeater Reserve

Used in 2016/17 for upgraded diplexer on UHF Radio Repeaters in Hopetoun and Munglinup.

Airport Reserve

To be used for the construction, reconstruction, repairs or modification of facilities including buildings, tarmac, airstrip and associated infrastructure at the Ravensthorpe Airport

Waste and Sewerage Reserve

To be used for the repair and/or construction of waste and sewerage facilities in the Shire of Ravensthorpe.

State Barrier Fence Reserve

To be used for the extension of the State Barrier Fence from Ravensthorpe to Esperance

Leave Reserve

To be used to fund long service leave and non-current annual leave requirements

10.1.2.1 ATTACHMENT

SHIRE OF RAVENSTHORPE

NOTES TO AND FORMING PART OF THE STATEMENT OF FINANCIAL ACTIVITY

FOR THE PERIOD ENDED 30 APRIL 2019

| | 2017/18 B/Fwd Per 2018/19 Budget \$ | 2017/18 B/Fwd Per Financial Report \$ | APRIL 2019 Actual \$ |
|--|--|--|-------------------------------|
| 5. NET CURRENT ASSETS | | | |
| Composition of Estimated Net Current Asset Position | | | |
| CURRENT ASSETS | | | |
| Cash - Unrestricted | (294,724) | (1,138,613) | (108,245) |
| Cash - Restricted Unspent Grants | 0 | 866,807 | 220,000 |
| Cash - Restricted Unspent Loans | 0 | 0 | 0 |
| Cash - Restricted Reserves | 3,802,027 | 3,802,028 | 1,218,733 |
| Receivables (Budget Purposes Only) | 0 | 0 | 0 |
| Rates Outstanding | 189,049 | 187,637 | 285,859 |
| Sundry Debtors | 58,758 | 58,759 | 63,094 |
| Provision for Doubtful Debts | 0 | 0 | 0 |
| Gst Receivable | 328,810 | 328,810 | 207,674 |
| Accrued Income/Payments In Advance | 4,369,362 | 4,380,244 | 10,881 |
| Loans - Clubs/Institutions | 0 | 0 | 0 |
| Inventories | 16,247 | 16,247 | 110,376 |
| | 8,469,529 | 8,501,919 | 2,008,372 |
| LESS: CURRENT LIABILITIES | | | |
| Sundry Creditors | (1,897,231) | (1,897,231) | (224,596) |
| Accrued Interest On Loans | (26,421) | (26,421) | 0 |
| Accrued Salaries & Wages | (28,464) | (28,464) | 0 |
| Income In Advance | 0 | 0 | 0 |
| Gst Payable | (66,980) | (12,767) | (7,041) |
| Payroll Creditors | 0 | (54,213) | (54,610) |
| Accrued Expenses | (330,595) | (379,105) | 0 |
| PAYG Liability | 0 | 0 | 0 |
| Other Payables | 0 | 0 | (64,799) |
| Current Employee Benefits Provision | (445,306) | (528,986) | (510,150) |
| Current Loan Liability | (201,680) | (201,680) | 0 |
| | (2,996,677) | (3,128,867) | (861,196) |
| NET CURRENT ASSET POSITION | 5,472,852 | 5,373,052 | 1,147,176 |
| Less: Cash - Reserves - Restricted | (3,802,027) | (3,802,028) | (1,218,733) |
| Less: Cash - Unspent Grants - Restricted | 0 | 0 | 0 |
| Add Back : Component of Leave Liability not Required to be Funded | 445,306 | 528,986 | 510,150 |
| Add Back : Current Loan Liability | 201,680 | 201,680 | 0 |
| Adjustment for Trust Transactions Within Muni | 0 | 0 | 1,318 |
| ESTIMATED SURPLUS/(DEFICIENCY) C/FWD | 2,317,811 | 2,301,690 | 439,911 |

SHIRE OF RAVENSTHORPE
NOTES TO AND FORMING PART OF THE STATEMENT OF FINANCIAL ACTIVITY
FOR THE PERIOD ENDED 30 APRIL 2019

6. RATING INFORMATION

| RATE TYPE | Rate in \$ | Number of Properties | Rateable Value \$ | 2018/19 Rate Revenue \$ | 2018/19 Interim Rates \$ | 2018/19 Back Rates \$ | 2018/19 Total Revenue \$ | 2018/19 Budget \$ |
|------------------------------------|-------------------|-----------------------------|--------------------------|--------------------------------|---------------------------------|------------------------------|---------------------------------|--------------------------|
| General Rate | | | | | | | | |
| GRV Residential | 0.112985 | 775 | 10,913,894 | 1,233,106 | 290 | | 1,233,396 | 1,235,814 |
| GRV Commercial | 0.126873 | 34 | 1,404,972 | 178,253 | | | 178,253 | 178,253 |
| GRV Industrial | 0.148920 | 35 | 512,772 | 76,362 | | | 76,362 | 76,362 |
| GRV Transient Workforce Accom | 0.301308 | 1 | 780,000 | 235,020 | | | 235,020 | 235,020 |
| GRV Short Stay Accommodation | 0.301308 | 1 | 72,800 | 21,935 | | | 21,935 | 21,935 |
| UV - Mining | 0.080000 | 64 | 2,164,211 | 173,137 | (618) | | 172,519 | 173,137 |
| UV - Rural | 0.009428 | 340 | 205,000,000 | 1,932,740 | (1,726) | | 1,931,014 | 1,929,007 |
| Non-Rateable Sub-Totals | | 1,250 | 220,848,649 | 3,850,553 | (2,055) | 0 | 3,848,498 | 3,849,528 |
| Minimum Rates | | | | | | | | |
| GRV Residential | 850 | 379 | 1,106,364 | 322,150 | | 0 | 322,150 | 323,850 |
| GRV Commercial | 850 | 9 | 44,740 | 7,650 | | 0 | 7,650 | 7,650 |
| GRV Industrial | 850 | 12 | 45,268 | 10,200 | | 0 | 10,200 | 10,200 |
| UV - Mining | 300 | 54 | 73,322 | 16,200 | | 0 | 16,200 | 16,500 |
| UV - Rural | 850 | 91 | 4,746,640 | 77,350 | | 0 | 77,350 | 76,500 |
| Sub-Totals | | 545 | 6,016,334 | 433,550 | 0 | 0 | 433,550 | 434,700 |
| Total Rates Ex Gratia Rates | | | | | | | 4,282,048 | 4,284,228 |
| Total Rates | | | | | | | 4,331,081 | |

All land except exempt land in the Shire of Ravensthorpe is rated according to its Gross Rental Value (GRV) in townsites or Unimproved Value (UV) in the remainder of the Shire.

The general rates detailed above for the 2018/19 financial year have been determined by Council on the basis of raising the revenue required to meet the deficiency between the total estimated expenditure proposed in the budget and the estimated revenue to be received from all sources other than rates and also bearing considering the extent of any increase in rating over the level adopted in the previous year.

The minimum rates have been determined by Council on the basis that all ratepayers must make a reasonable contribution to the cost of the Local Government services/facilities.

10.1.2.1 ATTACHMENT

SHIRE OF RAVENSTHORPE

NOTES TO AND FORMING PART OF THE STATEMENT OF FINANCIAL ACTIVITY

FOR THE PERIOD ENDED 30 APRIL 2019

7. TRUST FUNDS

Funds held at balance date over which the Municipality has no control and which are not included in this statement are as follows:

| Detail | Balance 01-Jul-18 \$ | Amounts Received \$ | Amounts Paid (\$) | Balance \$ |
|--|----------------------------|---------------------------|-------------------------|----------------|
| Builders Construction Industry Training Func | (25) | 4,700 | (2,243) | 2,432 |
| Bitumen Tender Document Bond | 487 | 0 | 0 | 487 |
| Building Registration Board Levy | 0 | 13,600 | (3,100) | 10,500 |
| Gym Swipe Card Bond | 10,062 | 2,160 | (840) | 11,382 |
| Hall Hire and Key Bonds | 5,393 | 5,400 | (5,550) | 5,243 |
| Hopetoun Tennis Club | 9,072 | 0 | 0 | 9,072 |
| Police Licensing Receipts | 2,717 | 0 | (2,690) | 27 |
| Candidate Nominations | 0 | 0 | 0 | 0 |
| Pavilion Hire Bonds | 1,233 | 0 | 0 | 1,233 |
| Ravensthorpe Cemetery Group | 76 | 0 | 0 | 76 |
| Rehabilitation Bond - Barmingo | 6,866 | 0 | 0 | 6,866 |
| Shire Staff Housing Bond | 0 | 0 | 0 | 0 |
| Rural Subdivisions Shed Bonds | 33,494 | 10,000 | 0 | 43,494 |
| Standpipe Swipe Card Bond | 2,800 | 400 | (150) | 3,050 |
| Subdivision Maintenance Bonds | 14,375 | 0 | 0 | 14,375 |
| Sundry Overpayments | 5,393 | 1,108 | (1,108) | 5,393 |
| Swimming Pool Key Deposits | 3,740 | 930 | (220) | 4,450 |
| Unknown Rates Payments | 1,719 | 266 | 0 | 1,985 |
| Flood Damage Donations | 400 | 0 | 0 | 400 |
| | <u>97,802</u> | <u>38,564</u> | <u>(15,901)</u> | <u>120,465</u> |

10.1.2.1 ATTACHMENT

SHIRE OF RAVENSTHORPE

NOTES TO AND FORMING PART OF THE STATEMENT OF FINANCIAL ACTIVITY

FOR THE PERIOD ENDED 30 APRIL 2019

8. OPERATING STATEMENT BY PROGRAM

| | APRIL 2019 Actual \$ | 2018/19 Adopted Budget \$ | 2017/18 Actual \$ |
|----------------------------------|-------------------------------|------------------------------------|-------------------------|
| OPERATING REVENUES | | | |
| Governance | 348 | 3,000 | 3,000 |
| General Purpose Funding | 5,120,677 | 5,364,428 | 5,974,936 |
| Law, Order, Public Safety | 308,766 | 225,190 | 273,528 |
| Health | 4,829 | 3,000 | 3,486 |
| Education and Welfare | 124,217 | 205,500 | 343,507 |
| Housing | 18,560 | 24,900 | 12,860 |
| Community Amenities | 464,926 | 699,097 | 758,411 |
| Recreation and Culture | 201,273 | 206,370 | 473,463 |
| Transport | 5,319,690 | 12,462,039 | 14,192,934 |
| Economic Services | 86,562 | 141,000 | 177,619 |
| Other Property and Services | <u>425,345</u> | <u>115,000</u> | <u>166,078</u> |
| TOTAL OPERATING REVENUE | 12,075,193 | 19,449,524 | 22,379,823 |
| OPERATING EXPENSES | | | |
| Governance | (516,625) | (641,955) | (512,935) |
| General Purpose Funding | (216,446) | (222,492) | (138,716) |
| Law, Order, Public Safety | (552,555) | (774,051) | (757,054) |
| Health | (233,599) | (278,922) | (311,402) |
| Education and Welfare | (273,648) | (372,723) | (474,312) |
| Housing | (187,536) | (258,313) | (178,558) |
| Community Amenities | (989,658) | (1,431,629) | (1,128,695) |
| Recreation & Culture | (1,318,506) | (1,800,572) | (1,789,627) |
| Transport | (11,343,844) | (13,686,930) | (15,921,409) |
| Economic Services | (262,832) | (349,466) | (343,179) |
| Other Property and Services | <u>(1,064,073)</u> | <u>(341,600)</u> | <u>(721,515)</u> |
| TOTAL OPERATING EXPENSE | (16,959,321) | (20,158,652) | (22,277,403) |
| CHANGE IN NET ASSETS | | | |
| RESULTING FROM OPERATIONS | <u>(4,884,128)</u> | <u>(709,128)</u> | <u>102,420</u> |

10.1.2.1 ATTACHMENT

SHIRE OF RAVENSTHORPE

NOTES TO AND FORMING PART OF THE STATEMENT OF FINANCIAL ACTIVITY

FOR THE PERIOD ENDED 30 APRIL 2019

8. OPERATING STATEMENT BY NATURE & TYPE

| | APRIL 2019 Actual \$ | 2018/19 Adopted Budget \$ | 2017/18 Actual \$ |
|---|---|--|----------------------------------|
| OPERATING REVENUES | | | |
| Rates | 4,333,799 | 4,279,228 | 3,996,775 |
| Operating Grants, Subsidies and Contributions | 5,730,608 | 11,240,622 | 15,606,969 |
| Non-Operating Grants, Subsidies and Contributions | 577,350 | 2,320,177 | 1,137,031 |
| Fees and Charges | 882,424 | 1,170,497 | 1,138,369 |
| Service Charges | 0 | 0 | 0 |
| Interest Earnings | 77,034 | 115,000 | 113,475 |
| Profit on Asset Disposals | 0 | 0 | 38,774 |
| Proceeds on Disposal of Assets | 92,727 | 350,000 | 296,008 |
| Realisation on Disposal of Assets | (92,727) | (350,000) | (296,008) |
| Other Revenue | 473,981 | 324,000 | 348,431 |
| TOTAL OPERATING REVENUE | 12,075,196 | 19,449,524 | 22,379,824 |
| OPERATING EXPENSES | | | |
| Employee Costs | (3,137,902) | (3,268,469) | (3,500,342) |
| Materials and Contracts | (10,469,683) | (12,637,507) | (15,005,173) |
| Utility Charges | (171,768) | (179,750) | (160,194) |
| Depreciation on Non-Current Assets | (2,485,832) | (3,302,576) | (2,715,493) |
| Interest Expenses | (61,660) | (85,280) | (96,095) |
| Insurance Expenses | (295,988) | (303,732) | (277,276) |
| Loss on Asset Disposals | (30,720) | (131,000) | (93,744) |
| FV Adjustment of Non-Current assets | 0 | 0 | 0 |
| Other Expenditure | (305,770) | (250,338) | (265,531) |
| TOTAL OPERATING EXPENSE | (16,959,323) | (20,158,652) | (22,113,849) |
| CHANGE IN NET ASSETS RESULTING FROM OPERATIONS | <u>(4,884,127)</u> | <u>(709,128)</u> | <u>265,975</u> |

10.1.2.1 ATTACHMENT

SHIRE OF RAVENSTHORPE

NOTES TO AND FORMING PART OF THE STATEMENT OF FINANCIAL ACTIVITY

FOR THE PERIOD ENDED 30 APRIL 2019

9. STATEMENT OF FINANCIAL POSITION

| | APRIL 2019 Actual \$ | 2017/18 Actual \$ |
|--------------------------------------|-------------------------------|-------------------------|
| CURRENT ASSETS | | |
| Cash and Cash Equivalents | 1,330,488 | 3,530,222 |
| Trade and Other Receivables | 567,509 | 4,955,449 |
| Inventories | 110,376 | 16,247 |
| TOTAL CURRENT ASSETS | 2,008,373 | 8,501,918 |
| NON-CURRENT ASSETS | | |
| Other Receivables | 24,618 | 24,618 |
| Inventories | 0 | 0 |
| Property, Plant and Equipment | 33,705,065 | 34,208,663 |
| Infrastructure | 25,016,829 | 25,172,799 |
| TOTAL NON-CURRENT ASSETS | 58,746,512 | 59,406,080 |
| TOTAL ASSETS | 60,754,885 | 67,907,998 |
| CURRENT LIABILITIES | | |
| Trade and Other Payables | 351,046 | 2,398,202 |
| Right of Use Asset | 98,617 | 98,617 |
| Long Term Borrowings | 0 | 201,680 |
| Provisions | 510,150 | 528,986 |
| TOTAL CURRENT LIABILITIES | 959,813 | 3,227,485 |
| NON-CURRENT LIABILITIES | | |
| Trade and Other Payables | 0 | 0 |
| Long Term Borrowings | 1,694,368 | 1,694,368 |
| Right of Use Assets | 1,015,248 | 1,015,248 |
| Provisions | 54,319 | 54,319 |
| TOTAL NON-CURRENT LIABILITIES | 2,763,935 | 2,763,935 |
| TOTAL LIABILITIES | 3,723,748 | 5,991,420 |
| NET ASSETS | 57,031,137 | 61,916,578 |
| EQUITY | | |
| Retained Surplus | 35,913,273 | 38,214,103 |
| Reserves - Cash Backed | 1,218,733 | 3,802,028 |
| Revaluation Surplus | 19,900,447 | 19,900,447 |
| TOTAL EQUITY | 57,031,137 | 61,916,578 |

SHIRE OF RAVENSTHORPE

NOTES TO AND FORMING PART OF THE STATEMENT OF FINANCIAL ACTIVITY

FOR THE PERIOD ENDED 30 APRIL 2019

10. FINANCIAL RATIOS

| | 2019 YTD | 2018 | 2017 | 2016 |
|-------------------------|-------------|------|------|--------|
| Current Ratio | 1.27 | 1.42 | 3.01 | 1.64 |
| Operating Surplus Ratio | 4.98 | 7.88 | 3.29 | (0.24) |

The above ratios are calculated as follows:

| | |
|-------------------------|--|
| Current Ratio | $\frac{\text{Current assets minus restricted current assets}}{\text{Current liabilities minus liabilities associated with restricted assets}}$ |
| Operating Surplus Ratio | $\frac{\text{operating revenue minus operating expense}}{\text{own source operating revenue}}$ |

10.1.2.1 ATTACHMENT

SHIRE OF RAVENSTHORPE
WORKS BUILDING MAINTENANCE BUDGET 2018/2019

Comments

| JOB | Description | Budget | Actuals | Comments |
|--------|--|--------|-----------|--|
| BM810 | Cub House | | 12,426.56 | |
| BM401 | Admin Building | | 17,456.39 | |
| BM001 | Jubilee Park Toilets | | 800.01 | |
| BM002 | Rangeview Park Toilets | | 613.42 | |
| BM003 | Munglinup Park Toilets | | 553.10 | |
| BM004 | Hopetoun Foreshore Toilets | | 731.01 | |
| BM005 | Kunoiup Walk Toilets | | 268.67 | |
| BM006 | Two Mile Beach Toilets | | 0.00 | |
| BM007 | Twelve Mile Beach Toilet | | 0.00 | |
| BM008 | Mason Bay Toilets | | 209.83 | |
| BM009 | Starvation Bay Main Toilets | | 279.01 | |
| BM010 | Starvation Bay Sub Toilets | | 0.00 | |
| BM011 | West Beach Toilets | | 234.09 | |
| BM012 | Hammersley Inlet Main Toilets | | 345.88 | |
| BM012A | Hammersley Inlet Toilets - Day Use | | 0.00 | |
| BM013 | Lee Creek Toilets | | 171.36 | |
| BM014 | Mcculloch Park Toilets | | 1,406.92 | |
| BM015 | Starvation Bay Toilets - Fishermans Camp | | 499.38 | |
| BM016 | Jerdacuttup Parking Bay Toilets | | 1,520.61 | |
| BM017 | Starvation Bay Toilets - Main Campark At Boat Ramp | | 0.00 | |
| BM018 | Mason Bay Toilets - Western End Of Camp Ground | | 0.00 | |
| BM101 | Ravensthorpe Tennis Club Pavilion | | 5,012.72 | |
| BM102 | Ravensthorpe Golf & Bowling Club | | 250.00 | |
| BM103 | Ravensthorpe Hand Gun Club | | 326.00 | |
| BM104 | Hopetoun Recreation Pavilion | | 3,713.39 | |
| BM105 | Hopetoun Golf Club | | 500.00 | |
| BM106 | Munglinup Recreation Pavilion | | 1,072.60 | |
| BM107 | Munglinup Golf Club | | 0.00 | |
| BM108 | Munglinup Equestrian Club | | 0.00 | |
| BM115 | Swimming Pool | | 2,312.08 | |
| BM121 | Fitzgerald Hall | | 978.99 | |
| BM122 | Jerdacuttup Hall | | 311.64 | |
| BM123 | North Ravensthorpe Hall | | 617.36 | |
| BM124 | Ravensthorpe Hall | | 13,264.08 | New Portico to Hall entry |
| BM125 | Hopetoun Community Centre | | 13,147.71 | |
| BM150 | Ravensthorpe Museum | | 138.69 | |
| BM154 | Ravensthorpe Recreation Centre | | 37,658.47 | LED Light Replacement program completed \$7K |
| BM170 | Ravensthorpe Crc | | 3,399.58 | |
| BM175 | Dunnart Art Building | | 6,117.76 | |
| BM201 | Ravensthorpe Works Depot | | 1,330.78 | |
| BM202 | Hopetoun Works Depot | | 2,759.04 | |
| BM205 | Airport Terminal Buildings | | 910.56 | |
| BM402 | 63 Morgan Street (Youth Group) | | 3,610.52 | |
| BM403 | 59-61 Morgans Street | | 0.00 | |
| BM703 | Hopetoun Drs Surgery | | 1,611.65 | |
| BM704 | Ravensthorpe Drs Surgery | | 1,651.76 | |
| BM801 | Ravensthorpe Senior Citizens Centre | | 345.89 | |
| BM802 | Hopetoun Senior Citizens Centre | | 948.55 | |
| BM803 | Ravensthorpe Aged Accommodation Units | | 0.00 | |
| BM804 | Hopetoun Aged Accommodation Units | | 0.00 | |
| BM811 | Little Barrens | | 1,146.46 | |
| BM901 | 4 Daw Street | | 1,725.22 | |
| BM903 | 18 Carlisle Street - Ceo | | 1,575.97 | |
| BM904 | 41 Kingsmill Street | | 556.39 | |

10.1.2.1 ATTACHMENT

| SHIRE OF RAVENSTHORPE | | | |
|---|--|-------------------|-------------------|
| WORKS BUILDING MAINTENANCE BUDGET 2018/2019 | | | |
| JOB | Description | Budget | Actuals |
| BM905 | 30 Kingsmill Street | | 616.70 |
| BM910 | 88 Martin Street | | 21,600.64 |
| BM914 | 93 Spence Street | | 14,321.41 |
| BM916 | Lot 79 Esplanade | | 1,488.40 |
| BM917 | 66 Queen Street | | 220.00 |
| BM918 | 27A Carlisle Street | | 1,556.21 |
| BM919 | 27B Carlisle Street | | 180.00 |
| BM920 | 27C Carlisle Street | | 1,730.41 |
| BM925 | 5 Daw Street - Doctors House | | 138.36 |
| | TOTAL BUILDING MAINTENANCE BUDGET | 601,100.00 | 186,382.43 |
| | | | 31% |

THIS PAGE LEFT BLANK INTENTIONALLY

10.2 MANAGER OF PLANNING AND DEVELOPMENT

10.2.1 PROPOSED SIGNAGE (LOLLIPOP) LOT 806 MORGANS STREET, RAVENSTHORPE

| | |
|--------------------------------|---|
| File Reference: | P19-04 |
| Location: | Lot 806 (89) Morgans Street, Ravensthorpe |
| Applicant: | Darren & Belinda Mcharg |
| Author: | Richard Hindley – Manager Strategic Planning & Land Projects |
| Authorising Officer: | Richard Hindley – Manager Strategic Planning & Land Project |
| Date: | 30 April 2019 |
| Disclosure of Interest: | Nil |
| Attachments: | 10.2.1.1 – Plans and Information 10.2.1.2 – Submissions – First round of Advertising 10.2.1.3 – Elevation Plans as Readvertised 10.2.1.4 – Submissions on Amended Plans 10.2.1.5 – Petition in support of proposal |
| Previous Reference: | Item 10.2.1 February 2019 Ordinary Meeting of Council |

Summary:

For Council to consider an application for the development of an oversized sign at Lot 806 (89) Morgans Street, Ravensthorpe.

Background:

Site Description

Lot 806 (89) Morgans Street, Ravensthorpe is 1,012m² in area and is currently developed as a shop being the Yummylicious Candy Shack.

Assessment:

The following are the zoning and Scheme requirements under Local Planning Scheme No. 6.

Lot 806 (89) Morgans Street is zoned 'Rural Townsite' by the Shire's Local Planning Scheme No. 6.

The objectives of the zone are as follows:

- i. To provide for a range of land uses that would typically be found in a small country town.*
- ii. To provide a flexible approach to development to encourage the growth of the townsites within the Shire of Ravensthorpe.*
- iii. Ensure the existing amenity and character of the townsites within the Shire of Ravensthorpe are retained by ensuring the compatibility of considered land uses.*
- iv. Ensure the efficient use of services and infrastructure within the Shire's townsites.*

The following provisions are contained in Local Planning Scheme No. 6:

4.12 Development in the Rural Townsite and Mixed Use Zones.

4.12.1 All development within the Rural Townsite and Mixed Use Zones shall have regard to any Local Planning Policy adopted by the local government.

- 4.12.2 All development within the Rural Townsite and Mixed Use Zones shall be of a design, and constructed from materials that complement the existing character and amenity of the zone as determined by the local government.
- 4.12.3 Residential development within the Rural Townsite and Mixed Use Zones is only permitted where it is proposed in conjunction with a non-residential land use or where an existing non-residential land use is operating. The local government may consider a standalone residential development where it can be demonstrated that it will not prejudice the primary street frontage to be used for non-residential land uses.
- 4.12.4 Residential development shall be permitted to a maximum density of R50 within the Rural Townsite and Mixed Use Zones. Any such residential development shall comply with the relevant requirements of the R-Codes as determined by the local government and clause 4.2.
- 4.12.5 All development within the Rural Townsite and Mixed Use Zones shall have due regard to the impact on existing residential development in terms of:
- a) Scale, bulk and height of proposed buildings;
 - b) The proposed activities associated with the land use including hours of operation; and
 - c) The general amenity of the area.
- 4.30 Building height
- 4.30.1 Except where provided elsewhere in the Scheme, the maximum height limits for buildings and structures above natural ground level throughout the Scheme Area irrespective of whether or not development approval is required pursuant to this Scheme is 10m.

Due to the nature of the proposed development the Advertising Signs Local Planning Policy applies.

| Sign Type | Maximum Height | Maximum Width | Maximum Area | Minimum Height of Sign Above NGL | Maximum Height of Sign Above NGL | Maximum Projection from Building | Minimum Setback to Front Boundary | Minimum Setback to Side Boundary | Special Requirements |
|--|----------------|---------------|-----------------|----------------------------------|----------------------------------|----------------------------------|-----------------------------------|----------------------------------|--|
| Pylon Sign | 6.0 m | | 4m ² | 2.75 m ** (see iv) | 6.0 m | - | - | 2.0 m | i. Exemptions: <ul style="list-style-type: none"> a. Where pylon signs are to be erected on a lot on which a factory tenement building or small shops are erected or are to be erected the Shire may require all pylon signs to be incorporated into one sign in which case: <ul style="list-style-type: none"> * all of the constituent or infill signs are of an equal size; and * one constituent or infill sign is provided for each business, shop or unit on the lot ii. One sign per tenancy/business; iii. be supported on one or more piers or columns of brick, stone, concrete, timber or steel of sufficient size and strength to support the sign under all conditions iv. May be permitted at less than 2.75m above NGL where located in a landscaping strip or similar |
| Compliance with Policy Standard (Y/N) | Y | | N | N* | N | - | - | Y | * If approved subject to a condition to have a landscaping strip under the sign. |

Under Clause 4.12.1 all development within the ‘Rural Townsite’ zone shall have regard to any Local Planning Policy adopted by the local government.

Under Clause 4.30.1 a structure (such as this sign) is not to exceed a height of 10m.

Schedule 2 Clause 3 (5) of the *Planning and Development (Local Planning Schemes) Regulations 2015* (Deemed Provisions) states:

- (5) In making a determination under this Scheme the local government must have regard to each relevant local planning policy to the extent that the policy is consistent with this Scheme.

A result of this Clause means that although the sign is taller than the Advertising Signs Local Planning Policy allows it is consistent with the Scheme requirement for the height and the sign complies with the Scheme in this respect.

The proposed development is not consistent with the Maximum Area for a Pylon Sign in Table 1 – Sign Specifications in the Advertising Signs Local Planning Policy. In this instance the maximum area under the policy is 4m² whereas the main portion of the sign exceeds 12m².

Comment:

The application has been referred to Council due to non-compliance with a Local Planning Policy as well as objections being received. A breakdown of the concerns outlined in the objection and submission can be found in the consultation section.

It should be noted that a Scheme Amendment is currently being prepared which will amend the Building Height clause by removing the reference to 'Structures'. This will leave the development control with the current policy standard.

The structure does not comply with Advertising Signs Local Planning Policy and as such the Officers Recommendation is for the refusal of the application as per the policy.

Options

Option 1 – Refuse

That Council resolve to refuse Development Application P19-04 for an oversized sign at Lot 806 (89) Morgans Street, Ravensthorpe for the following reason:

- 1) The proposed development is not consistent with the Maximum Area for a Pylon Sign in Table 1 – Sign Specifications in the Advertising Signs Local Planning Policy.

This is the officer recommendation as the proposal is inconsistent with a component of a Local Planning Policy. The administration is bound to the policy provision however an alternative recommendation is included as Council have the power to approve the development as it only needs to give regard to the Policy when making its decision.

Option 2 – Approve

That Council resolve to approve Development Application P19-04 for an oversized sign at Lot 806 (89) Morgans Street, Ravensthorpe subject to the following conditions:

- 1) Development shall be carried out and fully implemented in accordance with the details indicated on the stamped approved plans unless otherwise required or agreed in writing by the Shire of Ravensthorpe (Planning Services).
- 2) The area beneath the sign is to be landscaped to prevent pedestrian access under the sign and thereafter shall be maintained as landscaped areas at all times.
- 3) During construction stage, adjoining lots are not to be disturbed without the prior written consent of the affected owner(s).
- 4) The signs shall be kept clean and maintained free of dilapidation at all times to the satisfaction of the Shire of Ravensthorpe (Planning Services).

And the following advice notes:

- 1) **THIS IS NOT A BUILDING PERMIT.** An application for a building permit is required to be submitted and approved by the Shire of Ravensthorpe prior to any works commencing on-site.
- 2) The development is to comply with the *Building Code of Australia, Building Act 2011, Building Regulations 2012* and the *Local Government Act 1995*.
- 3) It is the responsibility of the applicant to ensure that building setbacks correspond with the legal description of the land. This may necessitate re-surveying and re-pegging the site. The Shire of Ravensthorpe will take no responsibility for incorrectly located buildings.
- 4) It is the responsibility of the developer to search the title of the property to ascertain the presence of any easements and/or restrictive covenants that may apply.
- 5) The applicant is to liaise with Shire of Ravensthorpe to ascertain the location of any and all shire infrastructure prior to the commencement of works.
- 6) Any requirement to move, relocate, repair or adjust existing shire infrastructure is to be at the cost of the applicant.

This option is presented to Council as it is not bound by the Local Planning Policy however it has to give it regard in making a determination.

Consultation:

The application was initially advertised on the Shire's webpage as well as the associated Facebook Page with advertising occurring between the 16 January and 30 January 2019. During the advertising seven (7) submissions were received.

The matters referred to in the submissions are summarised as follows. Please note that some submissions covered multiple points.

| Grounds of Objection | Planning Services Comments and Recommendation |
|--|---|
| General lack of support | Noted |
| Negative impact on visual amenity | There are potential impacts of the development on visual amenity however it is consistent with the current development on the site. |
| Not in keeping with established brand | Whilst it may be considered with the wider established brand within Ravensthorpe the proposed sign is in keeping with the style of the development on the subject site. |
| Concern about precedent | It is acknowledge that a precedent may be created by this proposal. It should however be noted that a Scheme Amendment is being prepared to default the height of a sign to the Local Planning Policy rather than the Scheme. |
| Possible compromise to lower to same height as the building | The structure's height complies with Clause 4.30.1 of Local Planning Scheme No. 6 which invalidates the height provision in the Local Planning Policy in this instance. |
| Want details on structure and materials when finalised | The structure of the sign is outlined in the application and the finish of the sign is to resemble a lollipop. |
| Want some link to the community – include a wildflower theme/art work. | Noted however the proponent has applied for a specific style of sign so this may not be possible. |
| Concern about health impacts of consuming too much sugar | The Development Application is for a sign. Whilst it may increase patronage to the associated store it is not considered that the overall health impact of the sign will be significant. |
| Request and emergency public meeting for residents of the Shire to be fully consulted | The Development Application was advertised in accordance with Clause 64 of Schedule 2 of the <i>Planning and Development (Local Planning Schemes) Regulations 2015</i> . |
| Not opposed to big things – can attract visitors to stop, however believes it should represent the town or area - include a wildflower theme/art work. | Noted however the proponent has applied for a specific style of sign so this may not be possible. |

As a result of Council's resolution at the February Ordinary Meeting of Council the application was readvertised on the Shire's webpage as well as the associated Facebook Page with advertising occurring between the 6 April and 20 April 2019. During the advertising six (6) submissions and a petition with 353 signatures were received in support of the proposal.

The matters referred to in the second round of submissions are summarised as follows. Please note that some submissions covered multiple points.

| Reason for Support | Planning Services Comments and Recommendation |
|---|---|
| General support | Noted |
| It would be a tourist attraction | Noted |
| Wildflower show is a 2 week exhibition and is not a reason why should stick to one direction of what the area has to offer. | Noted |
| It's a novel way to attract people to the town. | Noted |
| Need to improve offer to encourage tourists to stray in town and support town. | Noted |
| Achievement for town | Noted |
| Lollies and the like is a tourism industry applicable throughout the year. | Noted |
| Bright happy place that could attract tourist to town. | Noted |

The petition which was signed 353 times posed the following question:

By signing this document, you are acknowledging that the concept of having Ravensthorpe (The Yummylicious Candy Shack) hosting the Guinness world record for largest free-standing lollipop is something you support without exception!

Statutory Environment:

Local Planning Scheme No. 6

The applicant has a right of review to the State Administrative Tribunal if aggrieved by any planning decision.

Under Clause 4.12.1 all development within the Rural Townsite and Mixed Use Zones shall have regard to any Local Planning Policy adopted by the local government. Schedule 2 Clause 3 (5) of the Deemed Provisions also states that in making a determination under this Scheme the local government must have regard to each relevant local planning policy to the extent that the policy is consistent with this Scheme.

It should also be noted that pursuant to Section 211(1) of the *Planning and Development Act 2005*, a person aggrieved by the failure of a local government to enforce or implement effectively the observance of a local planning scheme may make representation to the Minister. If the Minister considers it appropriate to do so, representation may be referred to the State Administrative Tribunal for its report and recommendation. Following subsequent actions and recommendation by the SAT the Minister may order the local government to do all things considered necessary for enforcing the observance of the Scheme or any provisions of the Scheme.

Policy Implications:

Local Planning Policies are guidelines used to assist the local government in making decisions under the Local Planning Scheme and may address land use as well as development requirements. Although Local Planning Policies are not part of the Local Planning Scheme they must be consistent with, and cannot vary, the intent of the Local Planning Scheme provisions. In considering an application for Planning Approval, the local

government must have regard to a Local Planning Policy as required under Clauses 3(5) and 67 of the Deemed Provisions (set out in the *Planning and Development (Local Planning Schemes) Regulations 2015* Schedule 2.

Financial Implications:

None for Council

Strategic Implications:

The proposal is to do with the following theme of the Strategic Community Plan:
Theme 1:

A healthy, strong and connected community that is actively engaged and involved;
Outcome 1.2 “Vibrant & attractive townsite”.

Sustainability Implications:

- **Environmental:**

There are no known significant environmental considerations.

- **Economic:**

There are potential economic benefits to the Ravensthorpe townsite from the proposed signage by increasing patronage to the town centre and the flow-on effects of increased trade and patronage

- **Social:**

There are potential impacts of the development on visual amenity however it is consistent with the current development on the site.

Risk Implications:

| | |
|---|---------|
| Risk | Low (1) |
| Risk Likelihood (based on history and with existing controls) | Low (1) |
| Risk Impact / Consequence | Low (1) |
| Risk Rating (Prior to Treatment or Control) | Low (1) |
| Principal Risk Theme | Low (1) |
| Risk Action Plan (Controls or Treatment Proposed) | Low (1) |

Risk Matrix

| Consequence Likelihood | | Insignificant | Minor | Moderate | Major | Catastrophic |
|------------------------|---|---------------|------------|------------|--------------|--------------|
| | | 1 | 2 | 3 | 4 | 5 |
| Almost Certain | 5 | Medium (5) | High (10) | High (15) | Extreme (20) | Extreme (25) |
| Likely | 4 | Low (4) | Medium (8) | High (12) | High (16) | Extreme (20) |
| Possible | 3 | Low (3) | Medium (6) | Medium (9) | High (12) | High (15) |
| Unlikely | 2 | Low (2) | Low (4) | Medium (6) | Medium (8) | High (10) |
| Rare | 1 | Low (1) | Low (2) | Low (3) | Low (4) | Medium (5) |

A risk is often specified in terms of an event or circumstance and the consequences that may flow from it. An effect may be positive, negative or a deviation from the expected and may be related to the following objectives; occupational health and safety, financial, service interruption, compliance, reputation and environment. A risk matrix has been prepared and a risk rating of 1 has been determined for this item. Any items with a risk rating over 10 (considered to be high or extreme risk) will be added to the Risk Register, and any item with a risk rating over 17 will require a specific risk treatment plan to be developed.

Voting Requirements: Simple Majority

Recommendation:

That Council resolve to refuse Development Application P19-04 for an oversized sign at Lot 806 (89) Morgans Street, Ravensthorpe for the following reason:

- 1) The proposed development is not consistent with the Maximum Area for a Pylon Sign in Table 1 – Sign Specifications in the Advertising Signs Local Planning Policy.**

Moved: _____

Seconded: _____

APPLICATION Planning Approval

Application for Planning Approval

Schedule 2 Part 11 cl. 86- Application for development approval
Shire of Ravensthorpe

Application number
P19-4

Assessment number
AG48-

Permit authority **Shire of Ravensthorpe**

1. Property this application relates to

| | | | | | |
|---|-------------------------------|-------------------------|------------------------|--------------------|-------------------------------|
| Property street address | Unit No | Level | Street no 89 | Lot no | Street name Morgans |
| | Suburb Ravensthorpe | | | State WA | Postcode 6346 |
| Diagram or Plan No | | Certificate of Title No | | Folio | |
| Tile Encumbrances (e.g. easements, restrictive covenants) | | | | | |

Nearest Street Intersection

Is this lot vacant Yes No

2. Details of proposed development

Nature of development Works
 Use
 Works and use

Is an exemption from development claimed for part of the development? Yes No
If yes, is the development exemption for: Works and/or Use

Description of proposed works and/or land use:
Advertising sign.

Description of exemption claimed (if relevant)
NA.

Nature of any existing buildings and/or land use:
Retail shop.

Approximate cost of proposed development **\$ TBA.** Estimated time of completion **March 2019.**

10.2.1.1 ATTACHMENT

APPLICATION

Planning Approval

3. Owner details

| | | | | |
|---|---|--------------|------------|-----------|
| Owner(s) name(s) | Darrin & Belinda Mcharg | | | |
| ABN (if applicable) | | | | |
| Postal address | PO Box or street address | Suburb | State | Postcode |
| | PO Box 345 | Rawensthorpe | WA | 6346 |
| Contact person for correspondence: | Belinda Mcharg | | | |
| Email address | belinda4444@hotmail.com | | | |
| Phone/fax | Phone | Fax | Mobile | |
| | | | 0409525886 | |
| Owner(s) signature(s) |  | | | Date |
| | | | | 2/11/2019 |
| <i>The signature of the owner(s) is required on all applications. This application will not proceed without that signature. For the purposes of signing this application an owner includes the persons referred to in the Planning and Development (Local Planning Schemes) Regulations 2015 Schedule 2 clause 62(2).</i> | | | | |

4. Applicant details (if different to the owner)

| | | | | |
|---|--------------------------|--------|--------|----------|
| Applicant(s) name(s) | | | | |
| Postal address | PO Box or street address | Suburb | State | Postcode |
| | | | | |
| Contact person for correspondence: | | | | |
| Email address | | | | |
| Phone/fax | Phone | Fax | Mobile | |
| | | | | |
| <i>The information and plans provided for this application may be made available by the local government for public viewing in connection with the application.</i> | | | | |
| <input type="checkbox"/> Yes <input type="checkbox"/> No | | | | |
| Applicant(s) signature(s) | | | | Date |
| | | | | |

Office use only

Acceptance Officer's initials:



Date received:

2/11/2019

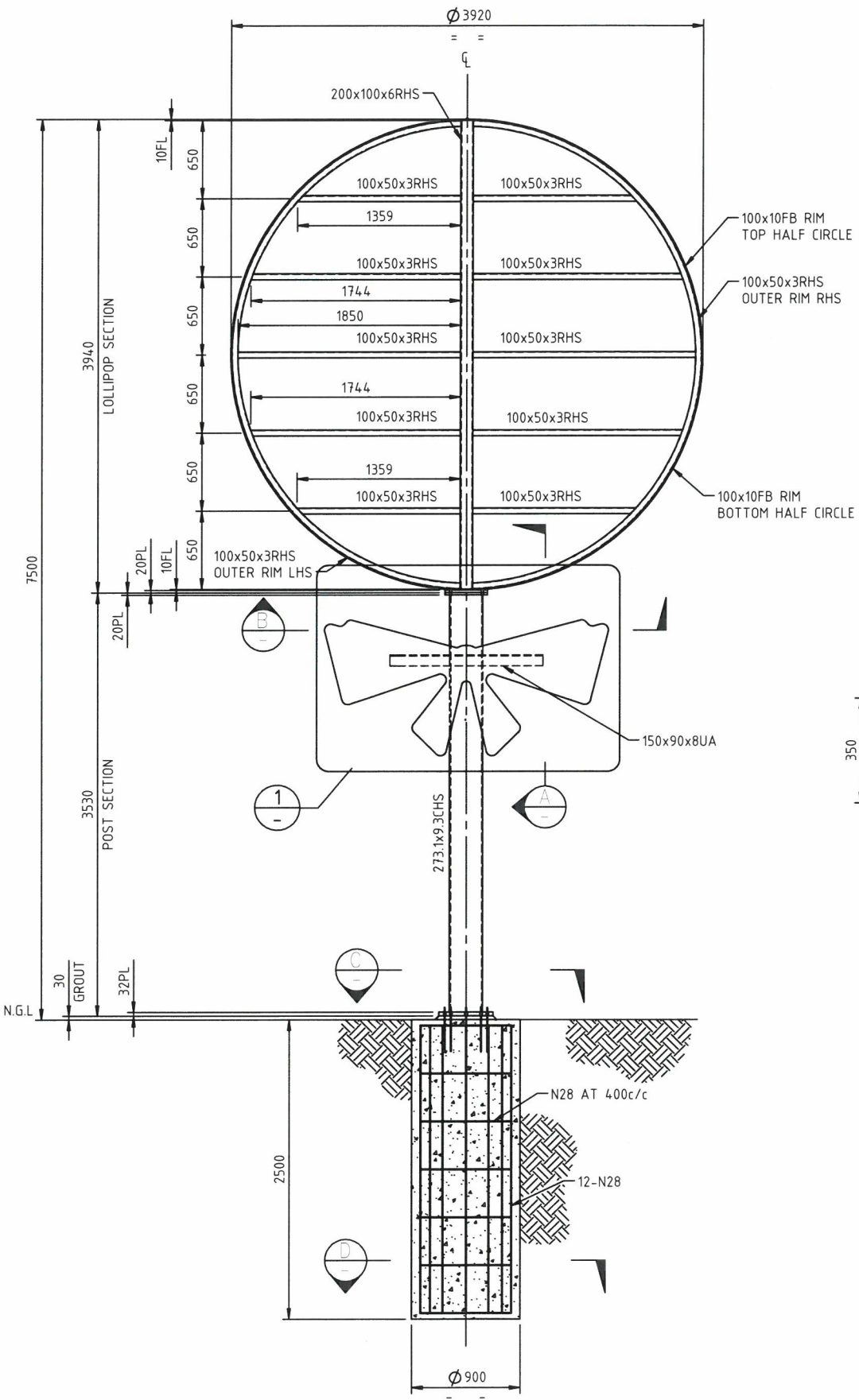

LOLLIPOP - ELEVATION
SCALE: 1:50

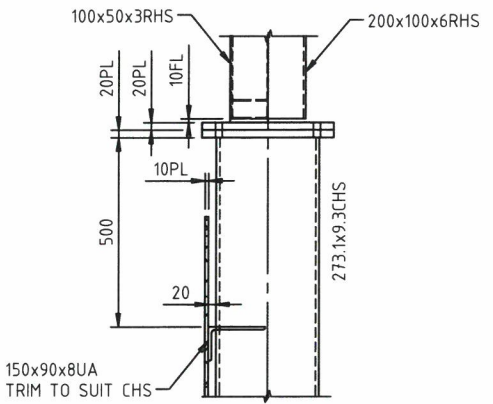

SECTION A
1:20

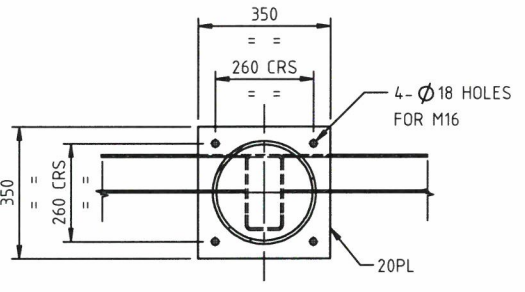

SECTION B
1:20

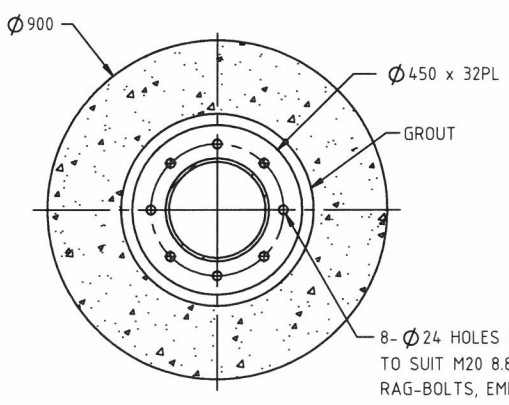

SECTION C
1:20

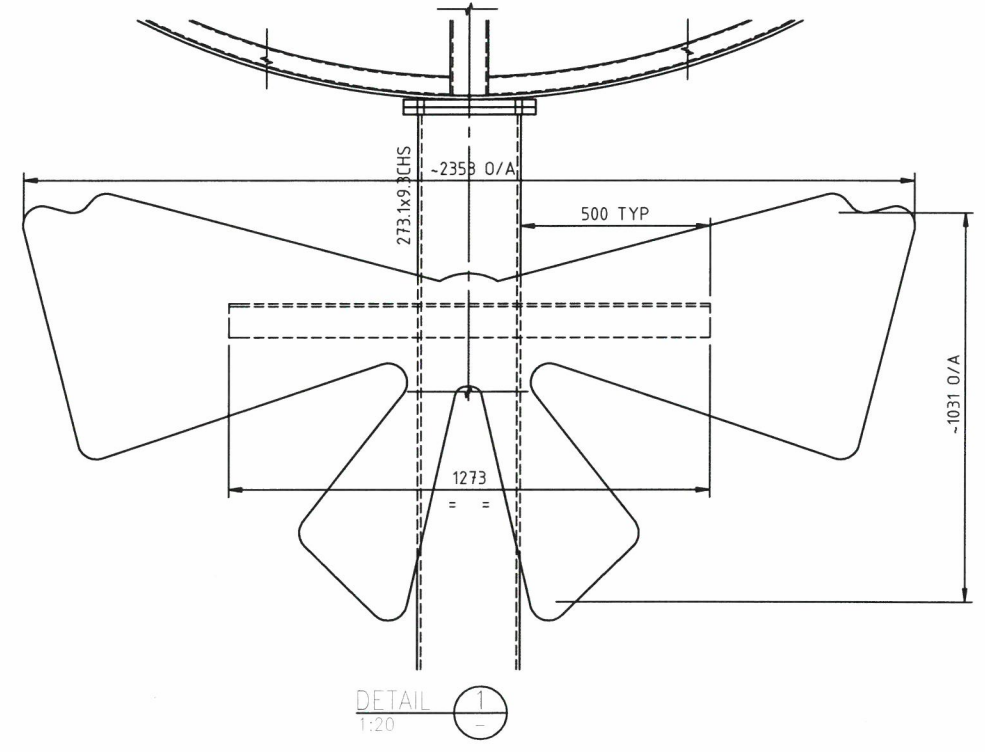

DETAIL 1
1:20

WELDING

1. ALL WELDS SHALL COMPLY WITH AS 1554 CATEGORY SP U.N.O
2. ALL FILLET WELDS SHALL BE AS FOLLOWS USING E48 XX OR W50 XX ELECTRODES U.N.O. MIN WELD TO BE 6mm FW CONTINUOUS U.N.O
3. ALL BUTT WELDS SHALL BE FULL PENETRATION CONTINUOUS USING E48 XX OR W50 ELECTRODES U.N.O
4. WELDS SHALL BE PREQUALIFIED TO AS 1554.3

GENERAL NOTES:

1. ALL DIMENSIONS ARE IN MILLIMETERS (mm) U.N.O
2. IF IN DOUBT, ASK

STEEL NOTES:

1. ALL OPEN SECTION STEEL SHALL BE GRADE C350L0 TO AS 3679.1 U.N.O
2. ALL PLATES, CLEATS, STIFFENERS ETC SHALL BE GRADE 350 TO AS 3679.1
3. REMOVE ALL BURRS, SHARP EDGES AND WELD SPATTER FROM STEEL WORK.
4. UNLESS SHOWN AS A BOLTED CONNECTION, ALL PLATES AND SECTIONS INDICATED IN CONTACT WITH EACH OTHER SHALL BE WELDED ALL ROUND.

| No. | DATE | REVISION | BY | ENG | APP |
|-----|----------|---------------------|----|-----|-----|
| B | 01.01.19 | ISSUED FOR APPROVAL | KT | - | - |
| A | 21.12.18 | ISSUED FOR COMMENT | KT | - | - |

REVISIONS

DISCLAIMER
THIS DRAWING AND ITS CONTENTS ARE ELECTRONICALLY GENERATED, ARE CONFIDENTIAL AND MAY ONLY BE USED FOR WHICH THEY ARE INTENDED. CPC ENGINEERING WILL NOT ACCEPT RESPONSIBILITY FOR ANY CONSEQUENCES ARISING FROM THE USE OF THE DRAWING FOR OTHER THAN ITS INTENDED PURPOSE OR WHERE THE DRAWING HAS BEEN ALTERED, AMENDED OR CHANGED EITHER MANUALLY OR ELECTRONICALLY BY ANY THIRD PARTY. LEGAL & EQUITABLE PROPERTY OF THIS DRAWING SHALL NOT PASS TO THE BUYER UNTIL FULL PAYMENT HAS BEEN RECEIVED.

NOTE
THIS IS AN UNCONTROLLED DOCUMENT ISSUED FOR INFORMATION PURPOSES ONLY. UNLESS THE CHECKED SECTIONS ARE SIGNED OR COMPLETED, FIGURED DIMENSIONS TAKE PRECEDENCE OVER SCALED. DO NOT SCALE REDUCED SIZE DRAWINGS. VERIFY DIMENSIONS PRIOR TO COMMENCING ANY ON-SITE OR OFF-SITE WORKS OR FABRICATION. IF IN DOUBT, ASK.

CPC RAVENSTHORPE Pty Ltd
ABN: 25 12 111 6283



6 MARTIN STREET
RAVENSTHORPE WA 6346
Tel: 08 9838 1555
Fax: 08 9838 1566

| DRAWN | KT | CHECKED | JG | APPROVED | JG |
|-------|----------|---------|----|----------|----|
| DATE | 21.12.18 | DATE | - | DATE | - |

YUMMYLICIOUS CANDY SHACK

| | | | | |
|-----------------------|------------|------|--|--|
| LOLLIPOP | | | | |
| CIVIL & STRUCTURE | | | | |
| ARRANGEMENT & DETAILS | | | | |
| SCALE | DRG No. | REV. | | |
| A3 AS SHOWN | 0414-S-001 | B | | |

10.2.1.1 ATTACHMENT

\$19k.



Richard Hindley

From: [REDACTED]
Sent: Wednesday, 30 January 2019 6:13 AM
To: Richard Hindley
Subject: Lollipop

Dear Mr Hindley,

I am writing you to let you know that I do not support the idea of a giant lollipop being erected within the Ravensthorpe town site.

Regards,

[REDACTED]

Message protected by MailGuard: e-mail anti-virus, anti-spam and content filtering.
<http://www.mailguard.com.au/mg>

[Report this message as spam](#)

ACTING CEO
SHIRE OF RAVENSTHORPE
PO Box 43
RAVENSTHORPE WA 6346

ATTENTION: RICHARD HINDLEY

RE: LOLLY POP STRUCTURE IN MORGANS ST

I would like to express the view that I think a giant lollypop in the main street will look ridiculous and detract from the very appropriate ambience that has now been achieved in Morgans St.

Surely we would like our town to be recognized for other values than a kitsch, grotesque confectionary structure?

Yours sincerely,
[Redacted Signature]

29/01/2019

[Redacted Initials]

29.1.19
box 178,
ravy 6346

To whom it may concern,

Hi, as a Ravensthorpe citizen and business owner in town, I'd like to offer my opinion on the proposal to alter/relax the rules for signage in town.

As a very long term resident of the area, I have seen the "personality" and reputation of the Ravensthorpe town & area, grow into a well respected and loved place - for its wilderness.

A huge effort and cost has recently gone into boosting this, with a fabulous street upgrade in town.

It is now lined with native gardens - in a nod to our environment - and as a business owner (bread and butter biz) in the middle of the tourist trade, I hear constant remarks from visitors about the natural beauty of the town.. they wouldn't have said that 18 months ago...

The town and main street are really growing and capitalizing on our hard-earned "brand"; of Ravensthorpe as a "Welcoming Wildemen" — It's on our number plates! And the "brand" has grown over decades, with immense hard work from the local community in putting on the famous, annual Wildflowers Show and promoting the Fitzgerald Biosphere as a very special natural place.

A very large lollipop on the main street is not in keeping with that brand.

The silos that have been painted in town are an example of the type of promotion that suits this area. They draw a huge crowd and celebrate the unique flora and fauna of our area — to great effect.

By all means a "normal" sized lollipop on the grounds of the Condy Shack. To change, or exempt, the standards

however, — just as the main street begins to flourish with local plants and new businesses that don't clash with the natural beauty, would be

a disaster.

10.2.1.2 ATTACHMENT

An oversized bottle on the bottle?

An oversized pack of ciggies on the pub?

An oversized coffee cup on the cafes?

No thanks.

We have a personality and an image.

It's working, please don't damage that.

Sincerely,



resident.

[Redacted]

[Redacted]

[Redacted]

Ravensthorpe WA 6346

27 Jan 2019

Dear Richard

Re: Proposed relaxation of development standards-Signage Lot 806 Morgans St
Ravensthorpe (P19-04)

Thank you for the opportunity to have a say in this matter.

It is my understanding that this sign is to be about 7.5m high.

Personally, I consider this completely out of character with what the Shire of
Ravensthorpe stands for, that being, 'The Welcoming Wilderness'.

We live in a special area and driving south east through town we look out over the
beautiful Ranges. In my opinion an extra-large tacky symbol comparable in size to
those that are put in towns across Australia would be nothing short of an eyesore
and definitely not part of the welcoming wilderness.

As a compromise perhaps the Shire could consider a sign the same height as the
building.

Regards

[Redacted]



Peter Wilks

From: [REDACTED]
Sent: Wednesday, 30 January 2019 4:02 PM
To: planner@ravensthorpe.wa.gov.au
Subject: Comment re Giant Lollypop Ravensthorpe

Peter Wilks
Town Planner
Shire of Ravensthorpe

Good afternoon Peter

May I make comment regarding the Giant Lollypop proposed for Ravensthorpe at the Candy Shop in Morgans Street.

We have been involved in discussions as we have offices for rental next door to where this artwork is proposed. We have asked for details of structure and materials when finalised, in consideration of our building and tenants next door, from a safety point of view. We have not yet received any information so do not know if details are finalised.

However, whilst we do not wish to detract from building a business and innovative ideas to do so, we would like to see some link to this town and community. Many volunteers have worked tirelessly over the years to build onto this regions strengths. The biodiversity in this Shire is now recognised interstate and internationally. Would it be possible to include a wildflower theme/artwork within the lollypop? This would reflect community and business working together – which is what we do.

I believe the Wildflower Show committee, their supporters and many who have worked to promote and protect our flora and fauna over the years, would appreciate this.

Thank you for the opportunity to comment.

Regards

[REDACTED]
[REDACTED]
[REDACTED]

Message protected by MailGuard: e-mail anti-virus, anti-spam and content filtering.
<http://www.mailguard.com.au/mg>

[Report this message as spam](#)

Richard Hindley

From: [REDACTED]
Sent: Wednesday, 30 January 2019 12:30 PM
To: Peter Wilks; Richard Hindley
Cc: [REDACTED]
Subject: Objection to Australia's largest lollypop
Attachments: Lollypop objection letter.docx

To Whom It May Concern:

I am writing to lodge my opposition to the 7.5m lollypop in Ravensthorpe that the proprietors of the ***Yummylicious Candyshack*** are proposing to build.

This is a terrible idea on so many levels that I have felt compelled to present a list as follows:

1. The structure will be an absolute eyesore in a town world-renowned for its dedication to wildflowers and ecology.
2. There is a deadly obesity and diabetes epidemic occurring in Australia that is caused by the chronic over consumption of sugar. A giant lollypop would only exacerbate this terrible situation; imagine the outrage if a local business proposed to erect a giant cigarette?
3. If Australia's largest lollypop is allowed to proceed, what's to stop other businesses building a giant Bundy rum bottle, giant coffee cup or giant hamburger? Do the residents of Ravensthorpe and its surrounds want to risk living in the San Gimignano of crass commercialisation?
4. The sheer naffness and crassness of such an endeavour will appeal to the dregs of Australian society. Indeed, it is not hard to imagine an endless caravan of fat tattooed bogans, armed with selfie-sticks, spoiling our precious wilderness by throwing their KFC and Macca's packets out the windows of their SS "Commodores", on their way to visit 'stralia's largest lollypop.

The sheer thought of Ravensthorpe playing host to Australia's largest lollypop is enough to make any reasonably enlightened person to cringe in shame and embarrassment. This must not be allowed to happen and, at the very least, the Council must call an emergency public meeting for the residents of the Shire of Ravensthorpe to be fully consulted.

I urge you to please give this matter your utmost consideration.

Yours faithfully,

[REDACTED]
Ravensthorpe
WA 6346
[REDACTED]

10.2.1.2 ATTACHMENT

Message protected by MailGuard: e-mail anti-virus, anti-spam and content filtering.

<http://www.mailguard.com.au/mg>

[Report this message as spam](#)

Peter Wilks

From: [REDACTED]
Sent: Wednesday, 30 January 2019 10:22 AM
To: Percy Craig
Subject: spam>Attn: Peter Wilkes - Lollypop

Hi Peter,

I believe today is the final day on which residents may comment on the proposal for a giant lollypop to be built in the main street of Ravensthorpe. I therefore humbly put forward my opinion.

I am not opposed to giant things in towns, in fact I think they can attract visitors to stop and they do draw attention to something of note. However, I believe, the something of note should represent the town or area. I wonder if the lollypop could be designed to have a wildflower in the middle, perhaps even a different one on each side - something bright and cheerful and representing Ravensthorpe's greatest asset.

Kind regards,

[REDACTED]

--

Message protected by MailGuard: e-mail anti-virus, anti-spam and content filtering.<http://www.mailguard.com.au/mg>

Click here to report this message as spam:

<https://console.mailguard.com.au/ras/1V0F25O3D8/2F0SyXqNv7vFgBBlaXUDiG/2.4>

10.2.1.3 ATTACHMENT



10.2.1.3 ATTACHMENT



Richard Hindley

From: [REDACTED]
Sent: Monday, 15 April 2019 11:36 AM
To: Richard Hindley
Cc: Ian Fitzgerald; Darrin & Belinda McHarg
Subject: Submission regarding lollipop proposal in Ravensthorpe.

Dear Richard,
I wish to voice my support for the giant lollipop proposal.

The lollipop is being erected on private property, owned by Belinda and her husband Darrin McCarg, alongside their business, Yummylicious candy shack at their own expense.

The lollipop will not have the business name written anywhere on it, but will have, 'Ravensthorpe WA', instead, as the venture is not proposed as a single business attraction but rather, a tourist attraction to the area to assist all businesses.

It is argued that we are a Wildflower town but those loudest in opposition to the lollipop are also those who knocked the proposal of metal flower sculptures being set up around our town. They, whilst crying for more tourists, are against any changes that will increase tourism.

The lollipop, whilst very different, is, in my opinion, one we need. Not everyone is into wildflowers, but most tourists are into visiting places that offer a unique sight and experience.

Having the giant lollipop will not only brighten our town, but draw tourists from all over the world. It is a feature for inclusion in the Guinness book of records: a feature bound to draw attention! And attention to help boost failing businesses, is a must!

Please do not allow the voices of a staid group of 'negative Nellies' put a stop to the lollipop proposal.
Yours sincerely

[REDACTED]

Message protected by MailGuard: e-mail anti-virus, anti-spam and content filtering.
<http://www.mailguard.com.au/mg>

[Report this message as spam](#)

Richard Hindley

From: [REDACTED]
Sent: Monday, 15 April 2019 11:29 AM
To: Richard Hindley
Subject: Large Lolly Pop Structure 89 Morgan's Street Ravensthorpe

Hi Richard

I'm just expressing my support for the Large Lolly Pop Structure at 89 Morgan's Street, as a small business owner in the Ravensthorpe Area I find it very disappointing that the owners of Yummylicious Candy Shack needs to jump through so many hoops to try and promote and improve their business exposure outside the Ravensthorpe Area.

Yes I'm very aware that Ravensthorpe is about country life style and Wildflowers, however our wildflower show is a 2 week exhibition which has received world wide reconnection through the hard work of some passionate and committed locals, which the communicate is totally grateful, however I don't see the reason why we should just stick to one direction on what the area has to offer.

It saddens me to think that the Ravensthorpe Wildflower is the only thing some people in the community think is our only asset.

Kinds Regards

[REDACTED]

Message protected by MailGuard: e-mail anti-virus, anti-spam and content filtering.
<http://www.mailguard.com.au/mg>

[Report this message as spam](#)

10.2.1.4 ATTACHMENT

Submission 3

Ravensthorpe Shire

As a local of Ravensthorpe for all my life (52 years), I am writing to SUPPORT the application from Yummylicious Candy Shack for their Big Lollypop sign.

Being a small country town I think it's very important to encourage all & any small operators of business within our town, while I understand that we are known for wildflowers in our region & the wildflower show is a major event it really only benefits the town for a couple of weeks during wildflower season.

Surely, having vibrant, colourful, & happy business's (such as the yummylicious candy shack) to add to the experience for the visitors to town is the best way to make lasting memories for them & promote Ravensthorpe as a must stop & see place.

As for the big lollypop I think it's a novel way to attract people to the down town area, this is not associated with where the wildflower show is based so will not conflict with the wildflower image of town rather add another feature for people to spend & support our town.

With the amount of full time travellers on the road all year round now they are looking for interesting places & things to do, for sure, get them to come see the Fitzgerald National Park, silo art & all our other amazing things but remember we need them to stay over in town & support our town, without business's this will not happen, if by putting up a big lollypop will help then it's definitely worth having a go, just like the big windmill promoting the historical farming area it's just another tool for the town to make use of. I would much prefer to see a big colourful lollypop than the mountains of dirt & wrecked bush you see as you come into town now.

So from my point of view Ravensthorpe needs people like Bel & Darrin who have put huge effort into our town & it's a no-brainer that they should be totally supported & encouraged with whatever is required from the shire to make this happen.

[REDACTED]

[REDACTED]

To Whom It May Concern..Shire.

I WOULD LIKE THE SHIRE TO CHANGE THE THOUGHTS ON WHAT AN ACHIEVEMENT FOR THIS TOWN, WOULD HIGHLIGHT THE LOLLY POP SHOP TO HAVE THIS :BIG LOLLY POP: ARRECTED FOR THE FUTURE OF TOURIST TO STOP AN SIGHT SEE OUR TOWN.PLUS THE FACT THAT BELL AN DARREN HAVE TRIED SO HARD TO ACHIEVE THIS, MY CREDIT TO THEM FOR DOING SUCH A WONDERFUL JOB.

OUR TOWN NEEDS AN UPLIFT AN IT IS BEING DONE BY THESE KIND OF GOOD PEOPLE . I REALISE ITS A SUGAR HIT SO TO SPEAK BUT A PERSON CAN BUY LOLLIES IN 3 PLACES HOTEL OTHER SHOPS,AN THE LOLLY POP SHOP HAS GLUTEN FREE LOLLIES AS WELL.

SO PLEASE ALLOW THIS TO CONTINUE IN WHAT THEY ARE TRYING TO IMPROVE TO ATTRACT VISITORS TO VISIT.

BELL AN DARREN ARE SO BRIGHT SPIRITED ONE COMES OUT OF THEIR SHOP HAPPY AN CONTENTED .THEY ARE GOOD PEOPLE THAT CAN DO THIS ..PARTYS FOR THE KIDS IS DELIGHTFUL TO SEE

.....SO PLEASE PASS THIS,TO BE DONE, NOT ONLY FOR THE PEOPLE.BUT FOR THE TOWN TO BE "MARKED " AS A HAVE TO CALL IN .!!!!!!.

.....IVE BEEN AROUND AN IN THIS TOWN SINCE 1978.....YOURS SINCERELY

.......... ..... 6/4/19.

10.2.1.4 ATTACHMENT

Submission 5

Mr. Pollock
Chief Executive Officer
Ravensthorpe Shire
Morgan Street
RAVENSTHORPE WA 6346

| | |
|-----------------------|--|
| Shire Of Ravensthorpe | |
| APPROVED FOR PAYMENT | |
| Goods Delivered: | |
| P/O Number: | |
| Job Number: | |
| Plant Number: | |
| Cost Centre: | |
| Signature: | |



HOPETOUN WA 6348

9th April 2019

Dear Mr. Pollock

I am writing to support the installation of the large structure of a lollipop in Morgan Street.

My reasons are:

- The Shire of Ravensthorpe is not only about our beautiful wildflowers.
- The wildflower season lasts for a specified time per year. Time is short.
- Lollies and the like is a tourism industry applicable throughout the year.
- All people, no matter what age, enjoy confectionary.
- The Shire of Ravensthorpe incorporates mining, farming and ocean history.
- The structure is to be placed alongside a building, not on the main path.
- There is a large bow on the structure saying 'RAVENSTHORPE WA'.
- No business name is evident highlighting that the name of the Ravensthorpe Shire can be recalled.
- Ravensthorpe is one gateway to Hopetoun. Tourism numbers fall when public holidays are finished.

Yours faithfully

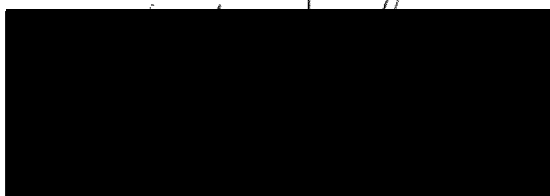

| | |
|-----------------------|-------------------------------------|
| SHIRE OF RAVENSTHORPE | |
| RECEIVED | |
| 10 APR 2019 | |
| File No. | 11648 |
| Doc ID: | 10219411865 |
| CEO / EA | <input checked="" type="checkbox"/> |
| DCEO / Finance | |
| Mgr Engineering | |
| Planning | <input checked="" type="checkbox"/> |
| Compliance / Airport | |
| Rec Services | |
| Building / Health | |
| Payroll | |
| Rates | |
| Synergise | |

10.2.1.4 ATTACHMENT

Dear Shire

My name is [REDACTED] and I'm 10 years old.

Submission 6

I'm writing to you about the Yummylicious Candy Shack.

I like going into Bel's shop as it's bright and a happy place to meet my friends.

The party Shack out the back is also fun and safe to play at.

I'm looking forward to the big lolly pop being put up as it will show visitors to our town where the happy bright colorful place to get lollies or an icecream after their lunch, plus the big lolly pop could attract tourists to our town.

Thank you

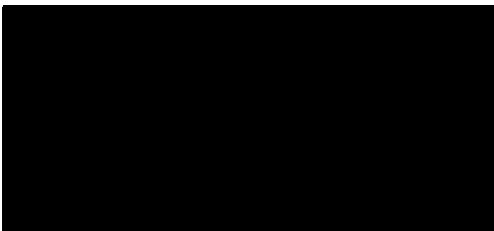

14/03/2019

353 Signatures

PARTY INVITATION

You're Invited to Celebrate with Us!

By signing this document, you are acknowledging that the concept of having Ravensthorpe (The Yummylicious Candy Shack) hosting the Guinness world record for largest free-standing lollipop is something you support without exception!

| | date | name | number | autograph |
|---|----------|----------------|-------------|--------------|
| ① | 23/02/19 | Belinda Mcharg | 0409 25886 | B Mcharg |
| ② | 23/2/19 | Jenny Elwin | 0421 8839 | J Elwin |
| ③ | 23/2/18 | Kylie Thomas | 0408 40447 | Kylie Thomas |
| ④ | 23/2/19 | DOUG JACKMAN | 0437 1336 | D Jackman |
| ⑤ | 23/2/19 | Jodi Edwards | 0423 81084 | J Edwards |
| ⑥ | 23/2/19 | Sarah Gaffney | 0423 55550 | S Gaffney |
| ⑦ | 24/2/19 | Riaan Coetzer | 0474 43 691 | R Coetzer |
| ⑧ | 24/2/19 | Willem Coetzer | 045659 22 | W Coetzer |
| ⑨ | 24/2/19 | Sharon White | 04663 9839 | S White |
| ⑩ | 24/2/19 | Karen Mcleish | 0416 720 | K Mcleish |
| ⑪ | 24/2/19 | Greg McCart | 04186 4815 | G McCart |
| ⑫ | 24-2-19 | Katie Paterson | 0403 77 799 | K Paterson |
| ⑬ | 24-2-19 | Jamie Paterson | " " | J Paterson |

2)

PARTY INVITATION

You're Invited to Celebrate with Us!

By signing this document, you are acknowledging that the concept of having Ravensthorpe (The Yummylicious Candy Shack) hosting the Guinness world record for largest free-standing lollipop is something you support without exception!

| | date | name | number | autograph |
|----|----------|----------------------|-------------|--------------------|
| 14 | 23/02/19 | Darrin McCharg | 0475 87755 | <i>[Signature]</i> |
| 15 | 24/2/19 | Aera Olszewski | 0400 33024 | <i>[Signature]</i> |
| 16 | 24/2/19 | Hayley Stinson | 0422 21 984 | <i>[Signature]</i> |
| 17 | 24/2/19 | Lisa Sutherland | 042 77 4601 | <i>[Signature]</i> |
| 18 | " | Georgina Sutherland | " | <i>[Signature]</i> |
| 19 | " | Charlotte Sutherland | " | <i>[Signature]</i> |
| 20 | " | Dylan Sutherland | " | <i>[Signature]</i> |
| 21 | " | Sally Sutherland | 0412 860146 | <i>[Signature]</i> |
| 22 | 24/2/19 | Connie Strom | 0449 8108 | <i>[Signature]</i> |
| 23 | " | Chris Strom | 0424 86578 | <i>[Signature]</i> |
| 24 | 24/2/19 | Nicole Rapp | 04074 0405 | <i>[Signature]</i> |
| 25 | 24/2/19 | Hamish Morton | 04087 5670 | <i>[Signature]</i> |
| 26 | 24/2/19 | Dale Andrews | 0409 1717 | <i>[Signature]</i> |
| 27 | 24/2/19 | Wayne | 04135 6660 | <i>[Signature]</i> |
| 28 | 24/2/19 | Ana W | 04178 4210 | <i>[Signature]</i> |

PARTY INVITATION

You're Invited to Celebrate with Us!

By signing this document, you are acknowledging that the concept of having Ravensthorpe (The Yummylicious Candy Shack) hosting the Guinness world record for largest free-standing lollipop is something you support without exception!

| | date | name | number | autograph |
|-----|---------|------------------|-------------|-------------------------|
| 28) | 24/2/19 | Shae Wilby | 04478 8873 | <i>Shae Wilby</i> |
| 29) | 24/2/19 | Steen Strandberg | Denmark | <i>Steen Strandberg</i> |
| 30) | — 1 — | Tom Strandberg | Denmark | <i>Tom Strandberg</i> |
| 31) | 24-2-19 | John Willoughby | 0437 81 883 | <i>John Willoughby</i> |
| 32) | 24-2-19 | Bobby Willoughby | 04133 4730 | <i>Bobby Willoughby</i> |
| 33) | 24-2-19 | GLENN BOOTHEY | 04478 2402 | <i>Glenn Boothey</i> |
| 34) | 24-2-19 | Margaret LeClerc | 0498 7700 | <i>Margaret LeClerc</i> |
| 35) | 24-2-19 | SHERYL HOROBIN | 040895 293 | <i>Sheryl Horobin</i> |
| 36) | 24-2-19 | BARRY STEICKE | 04080 5738 | <i>Barry Steicke</i> |
| 37) | 24-2-19 | MARK GURAYONI | 0427 30981 | <i>Mark Gurayoni</i> |
| 38) | 24/2/19 | Karina Smallman | 0428 3044 | <i>Karina Smallman</i> |
| 39) | 24-2-19 | Jerry Francis | 0427 81164 | <i>Jerry Francis</i> |
| 40) | 24/2/19 | Sue Coid | 0421 602 | <i>Sue Coid</i> |

PARTY INVITATION

You're Invited to Celebrate with Us!

By signing this document, you are acknowledging that the concept of having Ravensthorpe (The Yummylicious Candy Shack) hosting the Guinness world record for largest free-standing lollipop is something you support without exception!

| | date | name | number | autograph |
|-----|----------|--------------------|------------------|-----------|
| 41) | 24.2.19 | Karl Weber | G... .. | |
| 42) | 24.2.19 | Kath Mehen | 9439 803 | |
| 43) | 24.2.19 | Rechael Higgs | 0448 66637 | |
| 44) | 24.02.19 | Fabienne Mago | 043 39 46 47 | |
| 45) | 24.02.19 | Lisa Sooth | 049 11 820 18329 | |
| 46) | 24.2.19 | Valeria Amato | +41788 81410 | |
| 47) | 24-2-19 | JANE KERI | UK. | |
| 48) | 24/2 | JANNER DAMEN | 047530 290 | |
| 49) | 24/2 | Sebastian Dalebout | 0448 17956 | |
| 50) | 24/2-19 | DEB BOGELT | 0890 21760 | |
| 51) | 24/02-19 | Ryder Schofich | 04030 4809 | |
| 52) | 24/02/19 | Linda Smith | 0415 27126 | |
| 53) | 24/2/19 | Suzanne Hill | 042835 76 | |

PARTY INVITATION

You're Invited to Celebrate with Us!

By signing this document, you are acknowledging that the concept of having Ravenshorpe (The Yummylicious Candy Shack) hosting the Guinness world record for largest free-standing lollipop is something you support without exception!

| | date | name | number | autograph |
|-----|---------|-----------------------|---------------|--------------------|
| 54) | 24/2/19 | LISA Matler | 04590 680 | <i>[Signature]</i> |
| 55) | 24/2/19 | Luke Walker | 0428 1353 | <i>[Signature]</i> |
| 56) | 24.2.19 | Antonia Richardson | US | <i>[Signature]</i> |
| 57) | 25/2/19 | Reckel Red | MS 0417677916 | <i>[Signature]</i> |
| 58) | 25/2/19 | Butterwood | 045 040527 | <i>[Signature]</i> |
| 59) | 25/2/19 | Emagzy | 0476 4932 | <i>[Signature]</i> |
| 60) | 25/2/19 | Leanne Mayberry | 0409 9941 | <i>[Signature]</i> |
| 61) | 25/2/19 | Paul Williamson | 0408 71 215 | <i>[Signature]</i> |
| 62) | 25/2/19 | Bob Williamson | 9880 20. | <i>[Signature]</i> |
| 63) | 25/2/19 | GEOFF WALTON | 0419 2228 | <i>[Signature]</i> |
| 64) | 25/2/19 | NEIL PECHAR | 0408 37359 | <i>[Signature]</i> |
| 65) | 25/2/19 | LUCY PECHAR | | Lucy P |
| 66) | 25/2/19 | MOLLY PECHAR | | molly Pechar |

PARTY INVITATION

You're Invited to Celebrate with Us!

By signing this document, you are acknowledging that the concept of having Ravensthorpe (The Yummylicious Candy Shack) hosting the Guinness world record for largest free-standing lollipop is something you support without exception!

| | date | name | number | autograph |
|-----|------------|-----------------|------------|-------------|
| 67) | 24/02/2019 | John Smiley | 0428 725 | [Signature] |
| 68) | 24/02/2019 | Marshall Bacon | 0428 725 | [Signature] |
| 69) | 24/02/2019 | Damien Jones | 0407 48348 | [Signature] |
| 70) | 25/02/2019 | KLTN Hollow | 04399 7967 | [Signature] |
| 71) | 25/02/2019 | Quinten Knight | 0428 0044 | [Signature] |
| 72) | 25/02/2019 | Nicky Tesonero | 04481 81 | [Signature] |
| 73) | 25/2/2019 | Lyn Zacharko | 0422 738 | [Signature] |
| 74) | 25/2/2019 | Zac. Zacharko | 0438 7437 | [Signature] |
| 75) | 25-2-2019 | Bree Lawrence | 043938 17 | [Signature] |
| 76) | 25.2.2019 | KERRY LAWRENCE | 927 173 | [Signature] |
| 77) | 25.2.2019 | ROBERT MAULIFFE | 04174 02 | [Signature] |
| 78) | 25.2.2019 | Stephane Stacey | 045 74459 | [Signature] |
| 79) | 26-2/2019 | Tony Ferraro | 0476 55091 | [Signature] |

PARTY INVITATION

You're Invited to Celebrate with Us!

By signing this document, you are acknowledging that the concept of having Ravensthorpe (The Yummylicious Candy Shack) hosting the Guinness world record for largest free-standing lollipop is something you support without exception!

| | date | name | number | autograph |
|-----|---------|-------------------|----------------------|------------------------|
| 80) | 25/2/19 | ADAM TISDALE | 04316 7957 | <i>Adam</i> |
| 81) | 25/2/19 | Kelly Tisdale | 0432 76309 | <i>KTisdale</i> |
| 82) | 25/2/19 | Marie Mayberry | 0498 74355 | <i>Marie</i> |
| 83) | 25/2/19 | Kelly Power | 0400 73946 | <i>KPower</i> |
| 84) | 25/2/19 | TOM EDWARDS | 0429 73016 | <i>TE</i> |
| 85) | 25/2/19 | PROFESSOR J. WIND | | <i>Prof</i> |
| 86) | 25/2/19 | Kyle Macbean | 0487 755 0487 956546 | <i>Kyle</i> |
| 87) | 25/2/19 | Morgan Humphries | 0408 75952 | <i>Morgan</i> |
| 88) | 25/2/19 | Nicolai Biltoff | 457 23 805 | <i>Nicolai Biltoff</i> |
| 89) | 25/2/19 | Sea Magnusson | 0473 75 975 | <i>Sea Magnusson</i> |
| 90) | 25/8/19 | Alicia Bell | 0407 79562 | <i>Alicia</i> |
| 91) | 25/2/19 | James O'Sami | | <i>James</i> |
| 92) | 25/2/19 | James Ricciardol | 0419 74093 | <i>James</i> |

PARTY INVITATION

You're Invited to Celebrate with Us!

By signing this document, you are acknowledging that the concept of having Ravenshorpe (The Yummylicious Candy Shack) hosting the Guinness world record for largest free-standing lollipop is something you support without exception!

| | date | name | number | autograph |
|------|----------|--------------------|--------------|---------------------------|
| 93) | 25.02.19 | Adriana Smith | 04123 3881 | <i>Adriana Smith</i> |
| 94) | 25.02.19 | Thomas Spence | 04581 2756 | <i>Thomas Spence</i> |
| 95) | 25.2.19 | Hayley Wisenould | 04074 331 | <i>Hayley Wisenould</i> |
| 96) | 25/2/19 | Renzo Gasparini | 04283 71 | <i>Renzo Gasparini</i> |
| 97) | 25/2/19 | dayden Smith | 04479 248 | <i>Dayden Smith</i> |
| 98) | 26/2/19 | Arroy CAMPBELL | 04009 6807 | <i>Arroy Campbell</i> |
| 99) | 27/2/19 | MICK ASHTON | 0407 55604 | <i>Michael Ashton</i> |
| 100) | 27/2/19 | LINDA DEAN | 0455 66678 | <i>Linda Dean</i> |
| 101) | " | Sirs Jordan | 042 29 9797 | <i>Sirs Jordan</i> |
| 102) | " | Dore Francis | 0418 71 008. | <i>Dore Francis</i> |
| 103) | 27-2-19 | Deanne Webb | 0407 4754 | <i>Deanne Webb</i> |
| 104) | " " | Red & Lynn Row | 0404 396010 | <i>Red & Lynn Row</i> |
| 105) | 27-2-19 | ELIZABETH ABERLIWE | 04278 966 | <i>Ed. Aberliwe</i> |

9/

PARTY INVITATION

You're Invited to Celebrate with Us!

By signing this document, you are acknowledging that the concept of having Ravensthorpe (The Yummylicious Candy Shack) hosting the Guinness world record for largest free-standing lollipop is something you support without exception!

| | date | name | number | autograph |
|------|---------|----------------|------------|----------------|
| 106) | 27/2/19 | PETER KALALO | 0448 5105 | |
| 107) | 27/2/19 | R. Ross | 0429 81188 | |
| 108) | 27/2/19 | CHRISTINE ROSS | 059838 88 | Christine Ross |
| 109) | 28/2/19 | Luke Carrigan | 0413 4 568 | |
| 110) | 28/2/19 | LYN GIBSON | 0415 9938 | |
| 111) | 28/2/19 | JOHN GIBSON | 0417 5396 | |
| 112) | 28/2/19 | Oliver Cronin | 0455 2143 | oliver cronin |
| 113) | 28/2/19 | JANA ALLEN | 0413 6290 | |
| 114) | 28-2-19 | J. FERRIER | 04779 942 | |
| 115) | 28-2-19 | Val Bos | 04777 986 | Val Bos |
| 116) | 28/2/19 | Brook Fink | 0434 9649 | |
| 117) | 28-2-19 | ANDREW VENING | 042 83552 | |
| 118) | 28-2-19 | ERICA Power | | |

PARTY INVITATION

You're Invited to Celebrate with Us!







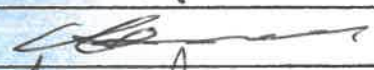
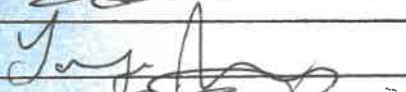

By signing this document, you are acknowledging that the concept of having Ravensthorpe (The Yummylicious Candy Shack) hosting the Guinness world record for largest free-standing lollipop is something you support without exception!

| | date | name | number | autograph |
|------|--------------------------|------------------|--------------|-------------|
| 119) | 28-2 | LYN | | [Signature] |
| 120) | 1/3/19 | Sharon | | [Signature] |
| 121) | 1/3/19 | Katy | Melbourne | [Signature] |
| 122) | 1/3/19 | WILL | PERTH. | [Signature] |
| 123) | 1/3/19 | JAKE | ONCEROR | [Signature] |
| 124) | 1/3/19 | Alyce | | [Signature] |
| 125) | 1/3/19 1/3/19 | Kate | ESPORNANCE | [Signature] |
| 126) | 1/3/19 | PETER HEPBURN | 0412 922 659 | [Signature] |
| 127) | 1/3/19 | RICHARD MAJOR | 907 9042 | [Signature] |
| 128) | 1/3/19 | Val | 989 2600 | [Signature] |
| 129) | 1/3/19 | Chad Altinier | 0412 911337 | [Signature] |
| 130) | 1/3/19 | Jenelle Altinier | 0424 67067 | [Signature] |
| 131) | 1/3/19 | JAMES BARETT | 0408 23396 | [Signature] |

PARTY INVITATION

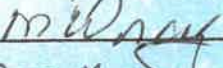
You're Invited to Celebrate with Us!

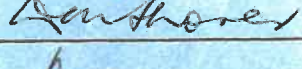
By signing this document, you are acknowledging that the concept of having Ravensthorpe (The Yummylicious Candy Shack) hosting the Guinness world record for largest free-standing lollipop is something you support without exception!

| | date | name | number | autograph |
|------|----------|---------------------|--------------|---|
| 132) | 28/02/19 | Diaby Taylor | +61 49 21891 |  |
| 133) | 28/02/19 | GARY JAMIESON | 0407 1987 |  |
| 134) | 28/02/19 | Tanya Medbury | 0447 9178 |  |
| 135) | 1/03/19 | Maria | 0422 71988 |  |
| 136) | 1/03/19 | CAROL HANSON | 04274 888 |  |
| 137) | 3/03/19 | M. Thuan | 0421 1420 |  |
| 138) | 7-3-19 | David Wregglesworth | 02247 841 |  |
| 139) | 6-2-19 | MARIS WRAVY | 045 3010 |  |
| 140) | 6/12/19 | ANDREW HARBORNE | 0412 3809 |  |
| 141) | 8/3/19 | Brian Henderson | 04290 780 |  |
| 142) | 8-3-19 | DEBORAH SCHORER | 04388 1022 |  |
| 143) | 15/11/19 | RONAN McLEWIS | 04660 11 |  |
| 144) | 17/03/19 | JOSE Ph/BINELL | 04150 7260 |  |

12

PARTY INVITATION

You're Invited to Celebrate with Us!

By signing this document, you are acknowledging that the concept of having Ravensthorpe (The Yummylicious Candy Shack) hosting the Guinness world record for largest free-standing lollipop is something you support without exception!

| | date | name | number | autograph |
|------|--------|------------------|--------------|-----------|
| 146) | 2/3/19 | Toni ARNET | 04010 719 | |
| 147) | 2/3/19 | harley wolfenden | 0488 9809 | |
| 148) | 2/3/19 | Karen Strudwick | 047 45819 | |
| 149) | 2/3/19 | CLAIRE KEMP | +4479 845478 | |
| 150) | 2/3/19 | Ben Keitz | 0409 15652 | |
| 151) | 2/3/19 | Jo Esteban | 0407 85437 | |
| 152) | 3/3/19 | Kim BRENNAND | 04199 186 | |
| 153) | 3/3/19 | Ian R Moss | 04000 9913 | |
| 154) | 3/3/19 | CUSHLA COULSON | 0456 24411 | |
| 155) | 3/9/19 | DON ATHINS | 04199 147 | |
| 156) | 3/9/19 | Peter Dickens | 044 18842 | |
| 157) | 3/9/19 | Hannah Dunkeld | 0427 26 217 | |
| 158) | 3/9/19 | Isabel Milne | 0421 28 48 | |

PARTY INVITATION

You're Invited to Celebrate with Us!

By signing this document, you are acknowledging that the concept of having Ravensthorpe (The Yummylicious Candy Shack) hosting the Guinness world record for largest free-standing lollipop is something you support without exception!

| | date | name | number | autograph |
|------|---------|-----------------|------------|-----------|
| 159) | 3/09/19 | Grace Dunkeld | 0488 7 286 | |
| 160) | 3/03/19 | Ross Dunkeld | 0428 05059 | |
| 161) | 3/3/19 | JESSIE FAIRHEAD | 98 38 283 | |
| 162) | 4/3/19 | Sam Farley | 0409 8828 | |
| 163) | 4/3/19 | KATE COOK | 0428 3465 | |
| 164) | 4/3/19 | Dez Gile | 0422 4159 | |
| 165) | 4/3/19 | MEL WILSON | 0402 80864 | |
| 166) | 4/3/19 | Adrian Lee | 0472 63 | |
| 167) | 4/3/19 | Kula-lee McKern | 0402 59401 | |
| 168) | 4/3/19 | Elisabeth Shaw | 0432 0 482 | |
| 169) | 4/3/19 | Rosie Currow | 0428 6048 | |
| 170) | 4/3/19 | Jo Hillerman | 0429 7 999 | |
| 171) | 4/3/19 | Kaye Brownley | 0428 744 9 | |

PARTY INVITATION

You're Invited to Celebrate with Us!

By signing this document, you are acknowledging that the concept of having Ravenshorpe (The Yummylicious Candy Shack) hosting the Guinness world record for largest free-standing lollipop is something you support without exception!

| | date | name | number | autograph |
|------|----------|-------------------|-------------|-----------------------|
| 172) | 4/3/2019 | Shirl | 0898 31266 | <i>SES</i> |
| 173) | 4/3/19 | Danelle | 0427 82565 | <i>Spencer</i> |
| 174) | 4/3/19 | Deli Jones | 0427 46 146 | <i>Deli</i> |
| 175) | 4/3/19 | Travis Jones | 0427 6 146 | <i>T Jones</i> |
| 176) | 4/3/19 | Kade Jones | 0477 21 741 | <i>Kade Jones</i> |
| 177) | 4.3.2019 | Danica Hampel | 04089 1994 | <i>Dampel</i> |
| 178) | 4-3-2019 | Di. Burton | 0428 26 134 | <i>DBurton</i> |
| 179) | 6.3.2019 | L. Green | 0417 2945 | <i>L Green</i> |
| 180) | 6.3.2019 | K. Butterworth | 0423 00 943 | <i>K. Butterworth</i> |
| 181) | 6.3.19 | F. GREGG | 0473 49 237 | <i>F Gregg</i> |
| 182) | 6.3.19 | E. Butterworth | 0423 00 943 | <i>E Butterworth</i> |
| 183) | 6.3.19 | MONIQUE MOUTON | 0410 06 896 | <i>Mo-mouton</i> |
| 184) | 6.3.19 | Noelene Jorgensen | 0438 41613 | <i>Jorgensen</i> |

PARTY INVITATION

You're Invited to Celebrate with Us!

By signing this document, you are acknowledging that the concept of having Ravensthorpe (The Yummylicious Candy Shack) hosting the Guinness world record for largest free-standing lollipop is something you support without exception!

| | date | name | number | autograph |
|-------|--------|--------------------|-------------|------------|
| (185) | 7-3-19 | KEN-HAYWARD | 2 | K Hayward |
| (186) | 7-3-19 | Rumis Bond | 98 09281 | R Rumis |
| (187) | 7-3-19 | PARYL LUCKMAN | 95 25625 | P Luckman |
| (188) | 7/3/19 | ALISON LUCKMAN | 0400 05211 | A Luckman |
| (189) | 7/3/19 | NATHAN POLLEN | 04952 799 | N Pollen |
| (190) | 7/3/19 | Shane Adams | 0457 66721 | S Adams |
| (191) | 7/3/19 | Ainsley Foulds | 0427 83078 | A Foulds |
| (192) | 7/3/19 | Jean Price | 0607 78312 | J Price |
| (193) | 7/3/19 | STEVE PRICE | 0406 677848 | S Price |
| (194) | 7/3/19 | IRINA BANDEN | 0415 17540 | I Banden |
| (195) | 8/3/19 | Courtney Hrabar | 0427 50068 | C Hrabar |
| (196) | 8/3/19 | Stephanie Stricker | 0411 80987 | S Stricker |
| (197) | 8/8/19 | SHAZ GARDNER | 0467 45181 | S Gardner |

PARTY INVITATION

You're Invited to Celebrate with Us!

By signing this document, you are acknowledging that the concept of having Ravensthorpe (The Yummylicious Candy Shack) hosting the Guinness world record for largest free-standing lollipop is something you support without exception!

| | date | name | number | autograph |
|------|---------|----------------------|------------|-------------|
| 198) | 1/3/19 | G. Oldfield | 04478 1723 | Gow |
| 199) | 1/3/19 | Kaleb Ebsary | 0400 388 | Kaleb Kaleb |
| 200) | 1/3/19 | T. Woodward | 0487 9672 | Woodward |
| 201) | 1.3.19 | R. Woodward | 04558 6021 | Dyballum. |
| 202) | 1.3.19 | A. Woodward | 0487 9672 | Woodward |
| 203) | 1.3.19 | Jeff Ace | 0417 6628. | Jeff |
| 204) | 1.3.19 | Michael James | 0427 0522 | MJ |
| 205) | 2.3.19. | Carolyn Koot | 0428 31354 | C |
| 206) | 2-3-19 | Bruce Montgomery | 04190 6821 | B |
| 207) | 2-3-19 | Jenn & Terry Russell | 0427 92136 | J & T |
| 208) | 2-3-19 | Melinda Mayberry | 04478 8311 | M |
| 209) | 2-3-19 | Jody HARR | 0400 0034 | Jody |
| 210) | 2-3-19 | JODY PRICE | 0438 11816 | Jody |

PARTY INVITATION

You're Invited to Celebrate with Us!











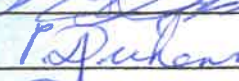

By signing this document, you are acknowledging that the concept of having Ravensthorpe (The Yummylicious Candy Shack) hosting the Guinness world record for largest free-standing lollipop is something you support without exception!

| | date | name | number | autograph |
|------|--------|-------------------|-------------|-----------------------------------|
| 211) | 8.3.19 | Berni Cameron | 041711662 | <i>Berni</i> ALWAYS stop here x10 |
| 212) | 8.3.19 | DICK BARDOWSKI | 04004842 | <i>Dick Bardowski</i> |
| 213) | 8.3.19 | ANN BARDOWSKI | | <i>A Bardowski</i> |
| 214) | 8.3.19 | Hazel Kendall | 040080512 | <i>Hazel</i> Very lovely stop |
| 215) | 8.3.19 | Stewart Kendall | 044049134 | <i>Stewart Kendall</i> |
| 216) | 8.3.19 | Skye Clarke Munro | 042360761 | <i>Skye Clarke Munro</i> |
| 217) | 8.3.19 | Ryan Roger | 04284098 | <i>Ryan Roger</i> |
| 218) | 8.3.19 | Mark Wiangnon | 04104232321 | <i>Mark Wiangnon</i> |
| 219) | 8.3.19 | ROSE BUTTERWORTH | 044788882 | <i>R. Butterworth</i> |
| 220) | 8.3.19 | Pamela Maker | 046009389 | <i>P. Maker</i> |
| 221) | 9.3.19 | GLORIA HUNT | 042894812 | <i>Gloria Hunt</i> |
| 222) | 9.3.19 | KEITH HUNT | 042918574 | <i>Keith Hunt</i> |
| 223) | 9.3.19 | Deb Jones | 04272838 | <i>Deb Jones</i> |

PARTY INVITATION

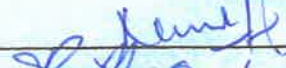
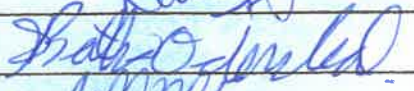
You're Invited to Celebrate with Us!

By signing this document, you are acknowledging that the concept of having Ravensthorpe (The Yummylicious Candy Shack) hosting the Guinness world record for largest free-standing lollipop is something you support without exception!

| | date | name | number | autograph |
|------|---------|-----------------------|-------------|---|
| 224) | 9/3/18 | Doug Jones | 0408 93114 |  |
| 225) | 9/3/19 | VIC 901 DUNSTON | 0438 7546 |  |
| 226) | 9/3/19 | Phil & Judy | 0419 91034 |  |
| 227) | 9/3/19 | Melissa Pollock | 0427 6286 |  |
| 228) | 9/3/19 | Sandra Linton | 0418 29015 |  |
| 229) | 9/3/19 | Amy Bayd | 0427 61263 |  |
| 230) | 9/3/19 | James Tindall | 0403 4432 |  |
| 231) | 9/3/19 | Sue Disborough | 0429 83350 |  |
| 232) | 9/3/19 | NIMRAT KAUR | 0429 941984 |  |
| 233) | 9/3/19 | Lavens, Botha-Odenaal | 0429 701 |  |
| 234) | 9/3/19 | Bree Botha-Odenaal | 04080 6299 |  |
| 235) | 10/3/19 | Wendy Price | 042813 498 |  |
| 236) | 0/3/19 | ASH TEMBLOEK | 043 183911 |  |

PARTY INVITATION

You're Invited to Celebrate with Us!

By signing this document, you are acknowledging that the concept of having Ravensthorpe (The Yummylicious Candy Shack) hosting the Guinness world record for largest free-standing lollipop is something you support without exception!

| | date | name | number | autograph |
|------|----------|------------------|-------------|------------------|
| 237) | 10/3/19. | Sue Horsington | | <i>Sue</i> |
| 238) | 10.3.19 | Greg Blazswan | | <i>Greg</i> |
| 239) | 11.3.19 | Teran Hira | | <i>TH</i> |
| 240) | 11.3.19 | Kat Richardson | | <i>Kat</i> |
| 241) | 11.3.19 | Dean Arnold | 0415 35526 | <i>Dean</i> |
| 242) | 13.3.19 | Mandyn Moore | 98 47632 | <i>M Moore</i> |
| 243) | 13.03.19 | Carmen White | 0497 19 295 | <i>C White</i> |
| 244) | 13.03.19 | Kylie Newman | 0407 5682 | <i>Kylie</i> |
| 245) | 13.03.19 | Kate Shaw | 0412 23 129 | <i>Kate Shaw</i> |
| 246) | " | Alex Shaw | 0427 0105 | <i>Alex Shaw</i> |
| 247) | 13.03.19 | MELISSA DENIESE | 0404 96822 | <i>Melissa</i> |
| 248) | 13.03.19 | CHRIS CARBERT | 0425 7306 | <i>Chris</i> |
| 249) | " " | Elizabeth Thomas | 042722 529 | <i>E Thomas</i> |

PARTY INVITATION

You're Invited to Celebrate with Us!

By signing this document, you are acknowledging that the concept of having Ravensthorpe (The Yummylicious Candy Shack) hosting the Guinness world record for largest free-standing lollipop is something you support without exception!

| | date | name | number | autograph |
|------|-----------|--------------------|-------------|--------------------|
| 250) | 14.3.19 | P. CONFORTI | 04133 0157 | P. Conforti |
| 251) | 14.3.19 | B. Stewart | 040961 65 | B. Stewart |
| 252) | 14-3-2019 | GEOFFRO FAIRHEAD | 0429 9023 | G. Fairhead |
| 253) | 14.3.2019 | Greg Johnson | 0403 29373 | Greg Johnson |
| 254) | 14.3.2019 | Penne metcay | 0428 776 | Penne metcay |
| 255) | 14.3.2019 | Steve Penner | 0898 1716 | Steve Penner |
| 256) | 14.3.2019 | DON BELL | 0409 95 974 | Don Bell |
| 257) | 14.3.2019 | Rebecca Green | 04477 0668 | Rebecca Green |
| 258) | 14.3.2019 | Julie Bell | 0403 74972 | Julie Bell |
| 259) | 14.3.2019 | Taytalan wisewould | 0407 0 337 | Taytalan wisewould |
| 260) | 15.3.2019 | Veronica Robertson | 0455 6 537 | Veronica Robertson |
| 261) | 15.3.2019 | MATTHEW ROBERTSON | 0455 6 537 | Matthew Robertson |
| 262) | 15.3.2019 | VERA MERRIS | 0409 2221 | Vera Merris |

PARTY INVITATION

You're Invited to Celebrate with Us!

By signing this document, you are acknowledging that the concept of having Ravensthorpe (The Yummylicious Candy Shack) hosting the Guinness world record for largest free-standing lollipop is something you support without exception!

| | date | name | number | autograph |
|------|----------|------------------|--------------|-------------------------|
| 263) | 15/3/19 | NOREEN JACKSON | 04555 6076 | <i>Noreen Jackson</i> |
| 264) | 15/3/19 | MARJ WELKE | 9071 311 | <i>M. Welke</i> |
| 265) | " | LYN HAMILTON | 04087 1335 | <i>L. Hamilton</i> |
| 266) | 15/3/19 | Freda Gilbert | 043998 867 | <i>Freda Gilbert</i> |
| 267) | 15/03/19 | KAY BONNETT | 04437 39444 | <i>Kay Bonnett</i> |
| 268) | 15/03/19 | Kath Thomas | 041 912 335 | <i>Kath Thomas</i> |
| 269) | 15/3/19 | ANDREW MARTIN | 0415 415836 | <i>A. Martin</i> |
| 270) | 15/3/19 | BRENDA TINK | 983 1035 | <i>B. E. Tink</i> |
| 271) | 15/3/19 | Claudia Gardiner | 0484 00662 | <i>Claudia Gardiner</i> |
| 272) | 15/3/19 | Sueheighton | 0407 981 301 | <i>Sueheighton</i> |
| 273) | 16/3/19 | Kat Saunders | 04380 2106 | <i>Kat Saunders</i> |
| 274) | 16/3/19 | Sophie Keen | 0447 19178 | <i>Sophie Keen</i> |
| 275) | 16/3/19 | Paul CORY | 0428 383 060 | <i>Paul Cory</i> |

PARTY INVITATION

You're Invited to Celebrate with Us!











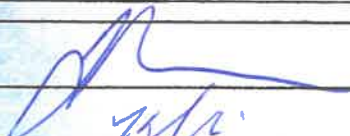
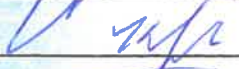

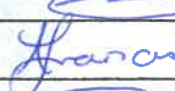
By signing this document, you are acknowledging that the concept of having Ravenshorpe (The Yummylicious Candy Shack) hosting the Guinness world record for largest free-standing lollipop is something you support without exception!

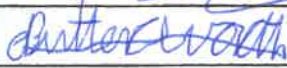
| | date | name | number | autograph |
|------|------------|--------------|-------------|--------------------|
| 264) | 27/3/19 | A. Plowman | 04016 4691 | AP |
| 265) | 27/3/19 | Jade. P | 0484 32 308 | <i>[Signature]</i> |
| 266) | 29/3/19 | Tyler | | Tyler |
| 267) | 29/3/19 | Ada. G | | Tyler |
| 268) | 29.03.2019 | J. Button | 04285 2010 | J Button |
| 269) | 30-03-19 | D. GRAVES | | D. Graves |
| 270) | 1-4-19 | L. Belli | | L. Belli |
| 271) | 1-4-19 | P. DONKIN | 0447 5845 | P. Donkin |
| 272) | 1-4-19 | Judith Kelly | 0400 56627 | J. Kelly |
| 273) | 3-4-19 | Kate Pains | 0427 57083 | Kate Pains |
| 274) | 3/4/19 | 1 'sa Ward | 9846 646 | 1sa Ward |
| 275) | " | Traig Ward | " | 1sa Ward |
| 276) | 5/4/19 | B. K Day | | B. K Day |

PARTY INVITATION

You're Invited to Celebrate with Us!

By signing this document, you are acknowledging that the concept of having Ravensthorpe (The Yummylicious Candy Shack) hosting the Guinness world record for largest free-standing lollipop is something you support without exception!

| | date | name | number | autograph |
|------|---------|-----------------------|-------------|---|
| 277) | 21/3/19 | Irralee | 0459 85027 |  |
| 278) | 22-3-19 | KEN ATKINSON (RANGER) | 043 44436 |  |
| 279) | 22-3-19 | JESSICA SOVANOVIC | 0435 02802 |  |
| 280) | 22.3.19 | Anthea Francis | 042 88432 |  |
| 281) | 22.3.19 | NICK WANELEY | 0484 84381 |  |
| 282) | 22.3.19 | ella Butterworth | |  |
| 283) | 22-3-19 | Clare Hemberton | |  |
| 284) | 22/3/19 | Cindy Gordon | 04736 815 |  |
| 285) | 22/3/19 | Aaron Arcig | 04771 460 |  |
| 286) | 23/3/19 | Annette Caelli | 9835 705 |  |
| 287) | 23/3/19 | meleena wych | 04673 164 |  |
| 288) | 23/3/19 | Kaylee Allison | 0400 48 246 |  |
| 289) | 27/3/19 | Mikayla Hair | 0421 8085 |  |

PARTY INVITATION

You're Invited to Celebrate with Us!

By signing this document, you are acknowledging that the concept of having Ravensthorpe (The Yummylicious Candy Shack) hosting the Guinness world record for largest free-standing lollipop is something you support without exception!

| | date | name | number | autograph |
|------|----------|---------------------|--------|----------------------------|
| 290) | 16/04/19 | Tracey Ross | | <i>Tracey Ross</i> |
| 291) | 17/04/19 | M Inskip | | <i>M Inskip</i> |
| 292) | 18-03-19 | Pauline Fitzpatrick | | <i>Pauline Fitzpatrick</i> |
| 293) | 18/3/19 | ADIN MCMILLON | | <i>Adin McMillon</i> |
| 294) | 18/3/19 | G&T FRANCIS | | <i>G&T Francis</i> |
| 295) | 18/3/19 | Sharon Schembi | | <i>Sharon Schembi</i> |
| 296) | 18/3/19 | Alan Pearson | | <i>Alan Pearson</i> |
| 297) | 18-3-19 | Dorethy Harris | | <i>Dorethy Harris</i> |
| 298) | 21.3.19 | BARBARA BOUTON | | <i>Barbara Bouton</i> |
| 299) | 21.3.19 | Angela Brown | | <i>Angela Brown</i> |
| 300) | 21.3.19 | Nicola Mason | | <i>Nicola Mason</i> |
| 301) | 21.3.19 | Sue Palmer | | <i>Sue Palmer</i> |
| 302) | 21-3-19 | Emma Palmer | | <i>Emma Palmer</i> |

PARTY INVITATION

You're Invited to Celebrate with Us!

By signing this document, you are acknowledging that the concept of having Ravensthorpe (The Yummylicious Candy Shack) hosting the Guinness world record for largest free-standing lollipop is something you support without exception!

| | date | name | number | autograph |
|------|-----------|-----------------|------------|-----------------|
| 303) | 2/4/19. | Wayne Parker | 0427 36269 | Wayne Park |
| 304) | 5/4/19 | TED KILBEY | 0427 7014 | Ed Kilbey |
| 305) | 5/4/19 | IRINA HENDERSON | 04370 303 | I. Henderson |
| 306) | 06/04/19 | ORCA JIMMON | 04266 246 | [Signature] |
| 307) | 10/4/2019 | KEVIN GARDNER | 0429 667 | [Signature] |
| 308) | 11 | RILEY | 04370 608 | [Signature] |
| 309) | 11 | COLLIER RILEY | | Ch Riley |
| 310) | 11 | RAY MILES | 0417 76755 | [Signature] |
| 311) | 11 | JENNY MILES | 0419 306 | Jenny Miles |
| 312) | 11/4/19 | CYNTHIA MAHER | 0428 66019 | Cynthia Maher |
| 313) | 11/4/19 | ANNABEL SHARKEY | 0401 2432 | [Signature] |
| 314) | 11/4/19 | JODI EDWARDS | 0429 31084 | J Edwards |
| 315) | 11/04/19 | Quentin Edwards | 0429 31087 | Quentin Edwards |

HOPEY
26

PARTY INVITATION

You're Invited to Celebrate with Us!

By signing this document, you are acknowledging that the concept of having Ravensthorpe (The Yummylicious Candy Shack) hosting the Guinness world record for largest free-standing lollipop is something you support without exception!

| date | name | number | autograph |
|--------|------------------------|------------|------------------------|
| 8/3/19 | Chloe Porteous | 0456202059 | corp |
| 8/3/19 | Debra Turpin | 0467695784 | Debra Turpin |
| 4/3/19 | A. Poole | 0408880991 | A. Poole |
| 9/3/19 | LEANNE BROOKS | 0477088733 | Leanne Brooks |
| 8/3/19 | Wendy Lani | 0427674458 | Wendy Lani |
| 9/3/19 | Ann Dingle | 0429383302 | Ann Dingle |
| 9/3/19 | M. Bell | 0429385040 | M. Bell |
| 9/3/19 | Wendy Pirgahay Egerton | 0447601557 | Wendy Pirgahay Egerton |
| 9/3/19 | LIZ MARTIN | 0415415836 | Liz Martin |
| 9/3/19 | Mary Smith | 98383917 | Mary Smith |
| 9/3/19 | Viv Henderson | 98383214 | Viv Henderson |
| " | Coralie Thomas | 98383128 | Coralie Thomas |
| 9/3/19 | CHRIS ZARNA | 0427103157 | Chris Zarina |
| 9/9/19 | Renelope Hale | 0488100244 | Renelope Hale |

HOPEY
27

PARTY INVITATION

You're Invited to Celebrate with Us!

By signing this document, you are acknowledging that the concept of having Ravensthorpe (The Yummylicious Candy Shack) hosting the Guinness world record for largest free-standing lollipop is something you support without exception!

| date | name | number | autograph |
|---------|-------------------|------------|----------------------|
| 6/3.19 | D WILLIAMS | 0428385012 | <i>D Williams</i> |
| 6/3.19 | G. Turner | 98357022 | <i>G Turner</i> |
| 6/3.19 | H. Taylor | 98383183 | <i>H Taylor</i> |
| 6/3/19 | Lola Pousdown | 0429381922 | <i>Lola Pousdown</i> |
| 6.5.19 | Valda Metz | 08381063 | <i>Valda Metz</i> |
| 6-3-19 | Kevin Sell | 0428464903 | <i>Kevin Sell</i> |
| 8/03/19 | Luz Sideman | 0898383933 | <i>Luz Sideman</i> |
| 8/03/19 | Rose Desveaux | | <i>Rose Desveaux</i> |
| 8/03/19 | I Burgess | | <i>I Burgess</i> |
| 8/3/19 | Erea Flanagan | 0429090722 | <i>E Flanagan</i> |
| 8/3/19 | Jane Lloyd | 0429383066 | <i>Jane Lloyd</i> |
| 8/3/19 | Lyn Flanagan | 0429020442 | <i>Lyn Flanagan</i> |
| 8/3/19 | Christine Burgess | 0448016018 | <i>C Burgess</i> |
| 8/3/19 | PAM COUSINS | 0428383117 | <i>P Cousins</i> |

THIS PAGE LEFT BLANK INTENTIONALLY

10.3 DIRECTOR OF TECHNICAL SERVICES

10.4 CHIEF EXECUTIVE OFFICER

11. ELECTED MEMBERS MOTIONS OF WHICH PREVIOUS NOTICE HAS BEEN GIVEN

12. BUSINESS OF AN URGENT NATURE INTRODUCED BY DECISION OF MEETING

12.1 ELECTED MEMBERS

12.2 OFFICERS

13. MATTERS BEHIND CLOSED DOORS

14. CLOSURE OF MEETING